

Instructions

Melt Pressure Sensor with SIL2 and PI'c'

PT190/PT192/PT193 Series



attestation

ISO 9001:2015

Please read this instruction manual carefully before installation



Content

- 1.Introduction
- 2.Application
- 3.Product features
- 4.Technical data
- 5.Dimensions
- 6.Electrical connection and debugging
- 7.Ordering Guide
- 8.Installation and Removal
- 9.Sensors cleaning
- 10.Transport and storage

Introduction

PT190/TP192/PT193 Melt pressure sensor adapt TI series high-performance digital chips. The circuit design is based on SIL2, PL'c' safety performance standards. The range limit is controlled through the relay output to ensure the safety of the extrusion equipment and production line, and effectively reduce the impact of damage and unpredictable personal safety accidents on the equipment due to pressure overload.

Application

PT190/TP192/PT193 melt pressure sensors are suitable for extrusion equipment and production lines with precise process control.

Product features

- Pressure range: 0~35bar to 0~2000bar
- Accuracy grade: $\pm 0.5\%$, $\pm 0.25\%$
- Remotely autozero via shorting 2pins together
- PL'c' safety performance level
- Special diaphragm coating, resistance to melt cooling adhesion diaphragm damage
- Digital-analog integrated circuit design, super anti-interference

Technical data

Pressure Range	0~35bar ; 0~2000bar	0~100bar ; 0~2000bar
Accuracy	±0.5% , ±0.25%	
Over load Pressure	1.5FSO	
Bridge Resistance	350Ω Wheatstone bridge	
Power	15~36Vdc	6~12Vdc
Output Signal	4~20mA	3.33mV/V
Relay Contact Performance	5~220Vdc , 1A , 0.2%FSO	
Relay Output	Open Output percent	10% , 20% ... 100%
Load Resistance (Ω)	<500Ω	--
Calibration	80%FSO	
Process Connection	M14×1.5 , 1/2UNF , M18×1.5	
Insulation Resistance(50Vdc)	1000MΩ	
Diaphragm Material	17-4PH , inconel718 , C276	
Diaphragm Max Temp	400°C	
Film Material	TiAlN	
E-connection	7-pin connector(Standard) , 8-pin connector	
Electrical Environment Temp	-20°C~85°C	
Thermocouple	J Type , E Type , K Type , pt100	
Protection Degree	IP65	
Installation Torque	<30Nm	
Filing Material	Mercury filing	

4...20mA Alarm output data

Power	Output	Relay status
Power off	No signal	On
Power off	< alarm point	Off
Power off	≥ alarm point	On
Power off	Abonormal point <3.6mA	On

Dimensions

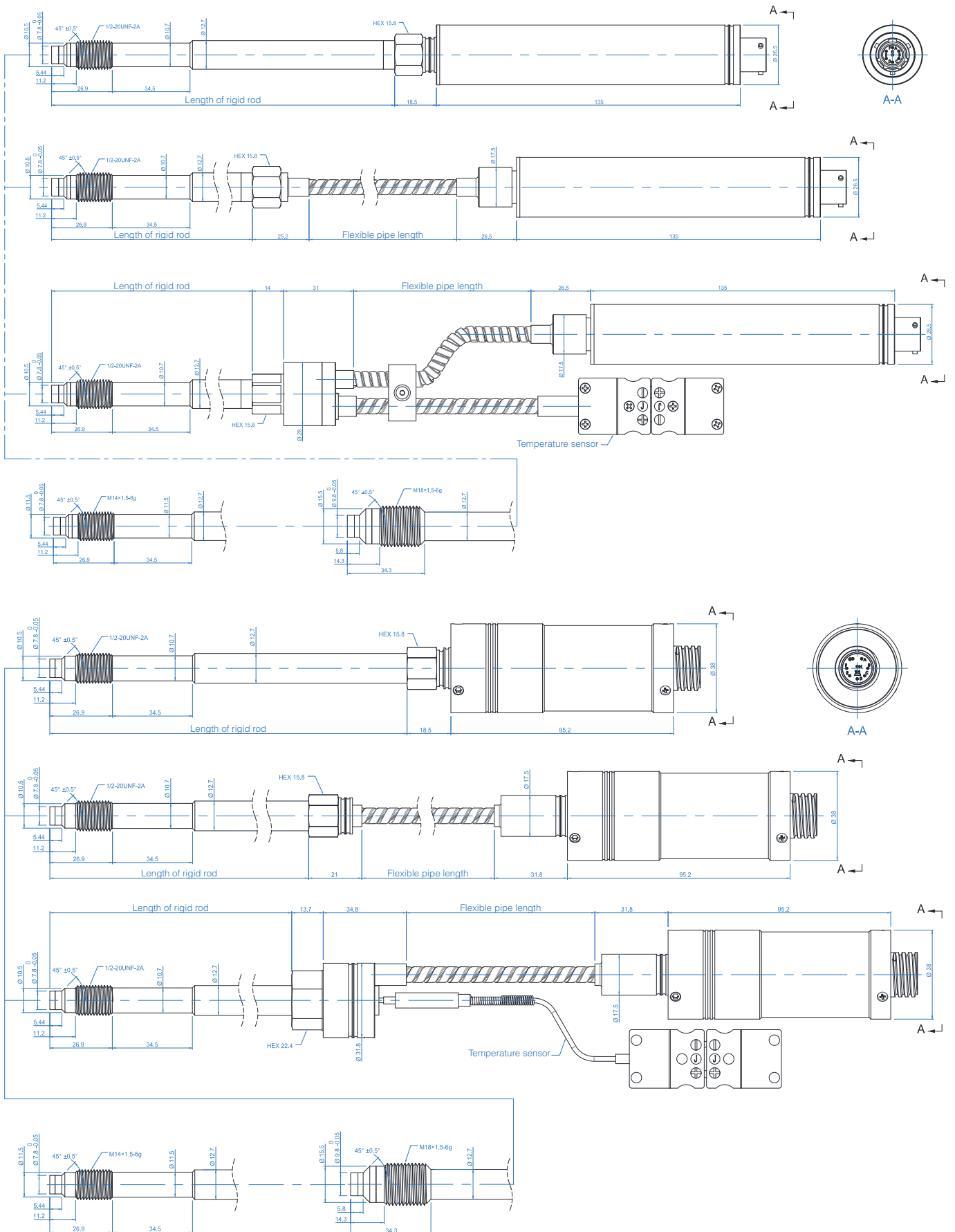

Electrical connection & Debugging

After the pressure sensor has been installed on the pipeline, the electrical connection must be carried out in accordance with the connection mode shown in the wiring diagram below. This series is equipped with an integrated amplifier circuit. The calibration process must be that the pipeline is heated and the pressure is zero, and the zero point is adjusted by activating the autozero function, which is started by shorting two pins together, mV signal does not have this function, can be rezero through the back-end instrument. Then 80% of the output signal is detected (see wiring diagram), and the pressure sensor (transmitter) will provide a standard 80% measured value signal.

4...20mA (3-wire)

(S3)7-pin connector :62IN-5016-10-7P-4-M(AMPHENOL)

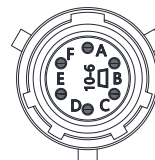
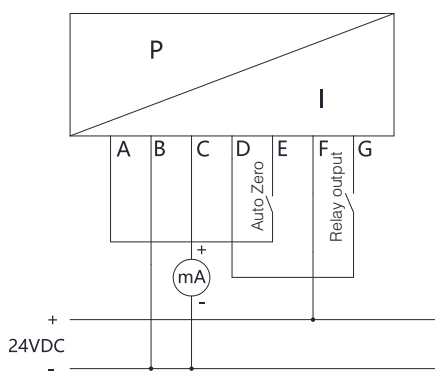

PIN	Function	Wire Color
A	Shorting A&E to rezero+	Red
B	Power- / Signal-	Black
C	Signal+	White
D	Relay output+	Green
E	Shorting A&E to rezero-	Blue
F	Power+	Yellow
G	Relay output-	Grey

4...20mA (3-wire)

(S9)8-pinconnector:M16 DIN/EN45326(Binder)

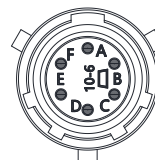
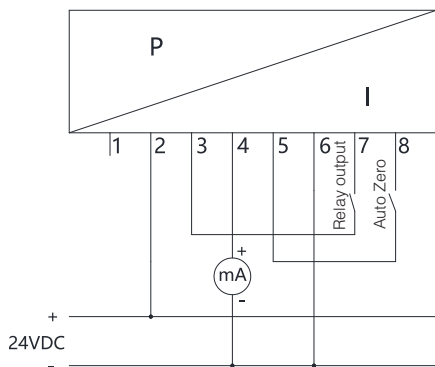

PIN	Function	Wire Color
1		Green
2	Power+	Red
3	Relay output+	Yellow
4	Signal+	Black
5	Shorting 5&8 to rezero+	Grey
6	Power- /Signal-	White
7	Relay output-	Blue
8	Shorting 5&8 to rezero-	Brown

4...20mA (3-wire)

(S6) 8-pin connector: PT02A-10-8P

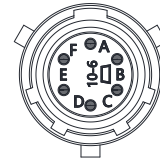
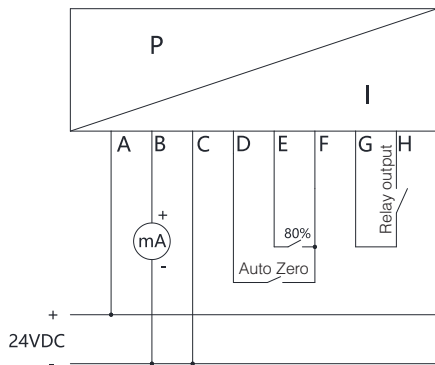

PIN	Function	Wire Color
A	Power+	Red
B	Power+	Block
C	Power- / Signal-	White
D	Shorting D&Fto rezero+	Green
E	80%+	Blue
F	Shorting D&Fto rezero-/80%-	Yellow
G	Relay output+	Grey
H	Relay output-	Brown

3.33mV/V (3-wire)

(S8) 8-pin connector: PT02A-10-8P

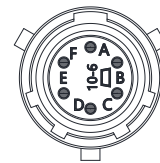
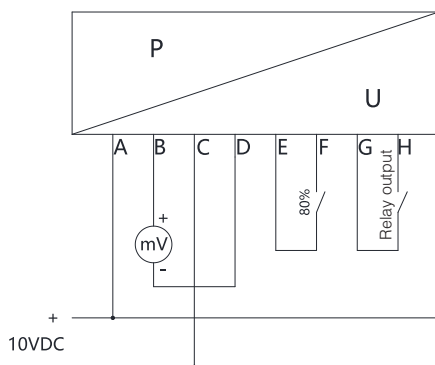

PIN	Function	Wire Color
A	Power+	Red
B	Signal+	Block
C	Power-	White
D	Signal-	Green
E	80%+	Blue
F	80%-	Yellow
G	Relay output+	Grey
H	Relay output-	Brown

Cable cable shall be made with shield cable, and the temperature resistance of each core shall not be less than 105 °C. Each core connection column shall be insulated and protected by heat shrink pipe, and the shield wire shall be connected to the plug metal. Special care shall be taken during cable welding, otherwise it may lead to wrong signal transmission or damage the product. It is recommended to use the welded special cable wire by Ziasiot . For excess wires in the cable, each wire shall be wrapped with insulating tape.

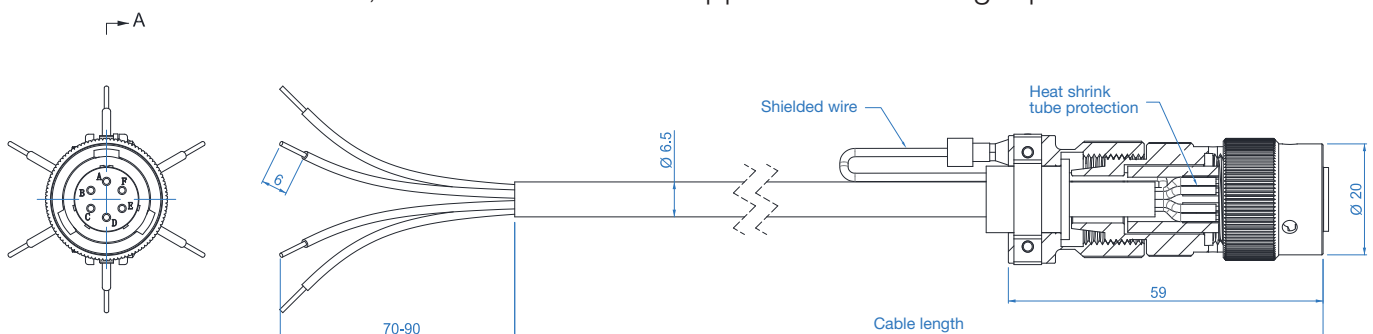

Ordering guide

Serie No	PT	X	-	X	-	X	-	X	-	X	-	X	-	X	-	X	-	X	-	X
Product type	Rigid Stem	190																		
	Rigid+flexible stem	192																		
	With thermocouple	193																		
Pressure range	3.5MPa 35bar 500psi			5C																
	10MPa 100bar 1500psi			1.5M																
	20MPa 200bar 3000psi			3M																
	35MPa 350bar 5000psi			5M																
	50MPa 500bar 7500psi			7.5M																
	70MPa 700bar 10000psi			10M																
	100MPa 1000bar 15000psi			15M																
	200MPa 2000bar 30000psi			30M																
Process connection	1/2-20UNF					1/2														
	M14×1.5					M14														
	M18×1.5					M18														
Rigid stem length	6inch (152mm)							6												
	9inch (229mm)							9												
	12.5inch (318mm)							12												
	15inch (381mm)							15												
	18inch (460mm)							18												
Flexible stem length	18inch (460mm)							/18												
	24inch (600mm)							/24												
	30inch (760mm)							/30												
Output signal	4~20mA 7-pin connector (p/n 62IN-5016-10-7P-4-M)(AMPHENOL)									S3										
	4~20mA 8-pin connector (p/n PT02A-10-8P)									S6										
	3.33mV/V 8-pin connector (p/n PT02A-10-8P)									S8										
	4~20mA 8-pin connector (p/n M16 DIN/EN45326) (Binder)									S9										
Thermocouple	J Type									J										
	K Type									K										
	Pt100									RTD1										
Rely alarm	70% rely output																			
	80% rely output																			
	90% rely output																			
	100% rely output																			
Filling medium	Mercury filling (Standard)																			--
	Alloy filling																			EP
Accuracy	0.50%																			--
	0.25%																			2A
Diaphragm	17-4PH (Standard)																			--
	Inconel718 (Anti-corrosive)																			17
	C276 (Anti-corrosive)																			C2

Installation & Removal

Installation

When installing the pressure sensor, the sensor hole should be within the size requirement marked in following drawing and the assembly accuracy can be checked by testing bolts. Before installing the sensor, first clean the impurities in the hole and between the threads, then the thread of the sensor is coated with heat-resistant slurry, the screw teeth can be avoided. The installation force is very important, the installation torque of the sensor can only act on the shaft (hexagon), do not apply any force to the head of the sensor. The housing should be kept away from high temperature areas.

1/2-20 UNF /M14×1.5= Maximum starting torque: 40Nm

M18 x 1.5 = Maximum starting torque: 50 Nm

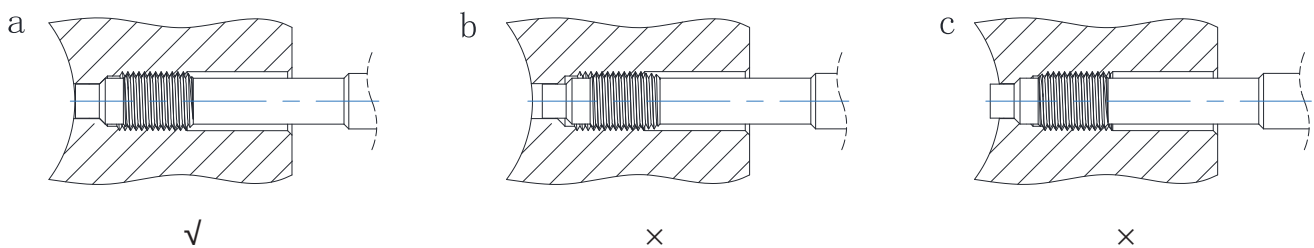

Removal

The removal of the pressure sensor must be done under heating conditions (plastic melting point). When removing the sensor, note that the diaphragm has no contact pressure. The force to unload the sensor must be applied only on the shaft (hexagon) and no force is applied to the head of the sensor.

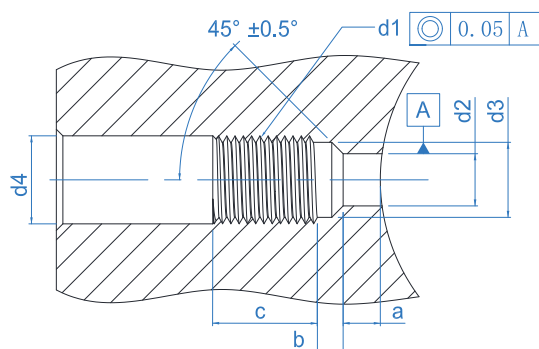

d1	M18×1.5	M14×1.5	1/2-20UNF-2A
d2	∅ 9.9 ^{+0.1}	∅ 7.9 ^{+0.1}	∅ 7.9 ^{+0.1}
d3	∅ 16.1 ^{+0.1}	∅ 11.7 ^{+0.1}	∅ 10.7 ^{+0.1}
d4	∅ 20	∅ 15	∅ 14
a	6.1 ^{-0.1}	5.7 ^{-0.1}	5.7 ^{-0.1}
b	4 ^{-0.2}	3.2 ^{-0.2}	3.2 ^{-0.2}
c	25	19	19

| Sensors cleaning

In order to clean the diaphragm, the sealing surface and thread of the transmitter must have the same temperature as the melting point of the plastic. The diaphragm and sealing surface can be cleaned with soft cloth, and the thread and rigid rod can be cleaned with steel brush or copper brush.

(Do not touch diaphragm surface with the steel brush.)

| Transport and storage

The removal of the pressure sensor must be done under heating conditions (plastic melting point). When removing the sensor, note that the diaphragm has no contact pressure. The force to unload the sensor must be applied only on the shaft (hexagon) and no force is applied to the head of the sensor.

Note: Mounting brackets, extension cables, connectors, cleaning kits, drill kits, dummy plug etc accessories, please contact with us.