

Instructions

Mercury-free Filling Melt Pressure Sensor

PT170/PT172/PT173 Series



attestation

ISO 9001:2015

Please read this instruction manual carefully before installation



Content

- 1.Introduction
- 2.Application
- 3.Product features
- 4.Technical data
- 5.Dimensions
- 6.Electrical connection and debugging
- 7.Ordering Guide
- 8.Installation and Removal
- 9.Sensors cleaning
- 10.Transport and storage

| Introduction

PT170/PT172/PT173 series adopts patented environmental friendly alloy filling and upgraded version of AFT vacuum filling technology, which are safe and non-toxic, high temperature resistance, and stable performance.

| Application

PT170 / PT172 / PT173 series are suitable for the control of the extrusion process of clean materials such as sheets, composite materials, films, pipes, food packaging, medical packaging, etc.

| Product features

- AFT technology environment-friendly alloy medium filling
- The highest temperature resistance can reach 400°C
- Several diaphragm materials are optional
- With SIL2 & RoHS certificate
- One-key rezero is easy to debug on site

Technical data

Pressure Range	0~35bar ; 0~2000bar	0~100bar ; 0~2000bar
Accuracy	±0.5% ; ±0.25%	
Over load Pressure	1.5FSO	
Bridge Resistance	350Ω Wheatstone bridge	
Output Signal	4-20mA	0~10Vdc , 0~5Vdc 3.33mV/V
Power	9~36Vdc(Standard24Vdc)	18~36Vdc 6~12Vdc(Standard10Vdc)
Load Resistance (Ω)	<(U-9)/0.02	>10k ---
Calibration	80%FSO	
Process Connection	M14×1.5 , 1/2UNF , M18×1.5	
Insulation Resistance(50Vdc)	1000MΩ	
Diaphragm Material	17-4PH , inconel718 , C276	
Diaphragm Max Temp	400°C	
Film Material	TiAIN	
E-connection	6-pin connector(Standard) , 8-pin connector(Standard)	
Electrical Environment Temp	-20°C~85°C	
Thermocouple	J Type , E Type , K Type , pt100	
Protection Degree	IP65	
Installation Torque	<30Nm	
Filing Material	ATF Alloy-filling	

Dimensions

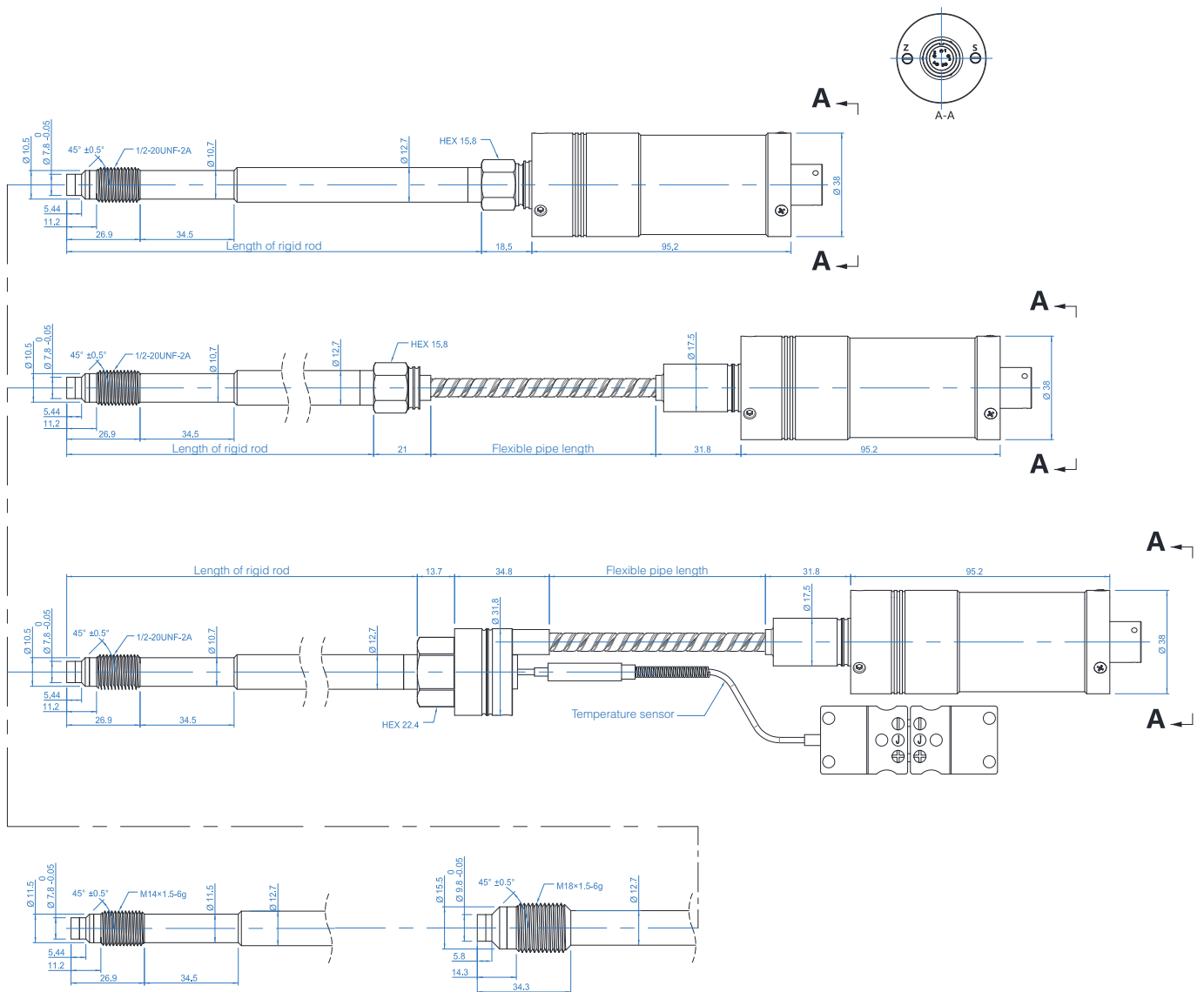

Electrical connection & Debugging

After the pressure sensor has been installed on the line, the electrical connections must be made as shown in the wiring diagram below.

The PT170 / PT172 / PT173 series is equipped with an integrated amplification circuit, the calibration process must be the pipeline is heated and the pressure is zero. The zero point is adjusted by activated autozero function, which is via shorting two pins together (see wiring) or adjusted by twisting the "Z" position screw at the top of the shell with an object like toothpick, press button 3 seconds to reset zero (please do not touch S" point).mV signal without this function, can reset zero through the back - end instrument. The output signal is then detected by 80% (see the wiring diagram), and it will provide a signal of a standard 80% measurement.

3.33mV/V (4-wire)

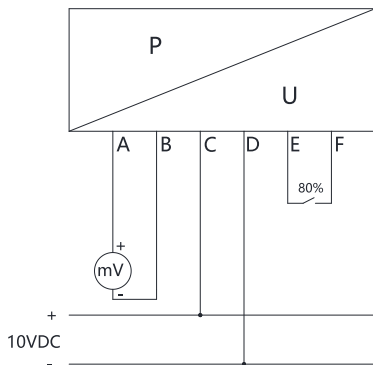

6-pin connector /PT02A-10-6P

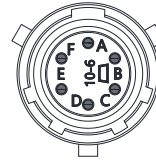

PIN	Function	Wire Color
A	Signal+	Red
B	Signal-	Black
C	Power+	White
D	Power-	Green
E	80%+	Blue
F	80%-	Orange

4...20mA (2-wire) (Auto zero)

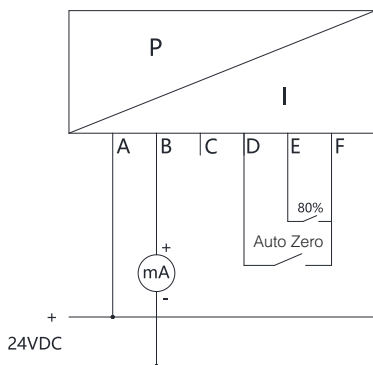

6-pin connector /PT02A-10-6P

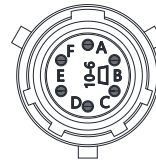

PIN	Function	Wire Color
A	Power+	Red
B	Power-	Black
C		White
D	Shorting D&F to rezero+	Green
E	80%+	Blue
F	Shorting D&F to rezero+/80%-	Orange

4...20mA (2-wire) (One key to reset zero)

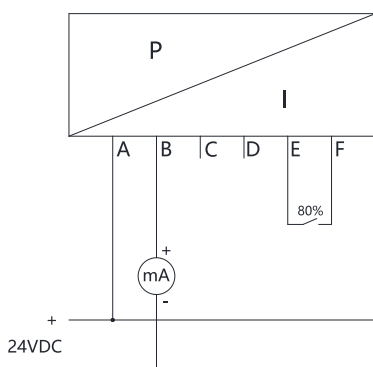

6-pin connector /PT02A-10-6P

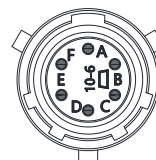

PIN	Function	Wire Color
A	Signal+	Red
B	Signal-	Black
C	Power+	White
D	Power-	Green
E	80%+	Blue
F	80%-	Orange

0...5V/10V (4-wire) (Auto zero)

6-pin connector /PT02A-10-6P

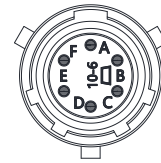
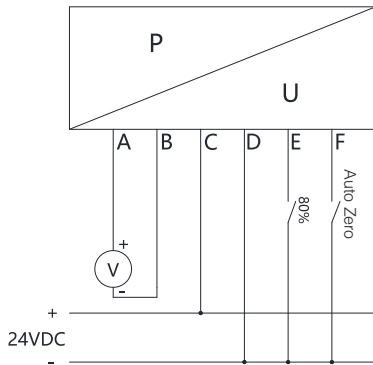

PIN	Function	Wire Color
A	Signal+	Red
B	Signal-	Black
C	Power+	White
D	Power- / 80%- / Shorting D&F to rezero-	Green
E	80%+	Blue
F	Shorting D&F to rezero+	Orange

*B and D pins are connected internally

0...5V/10V (4-wire) (One key to reset zero)

6-pin connector /PT02A-10-6P

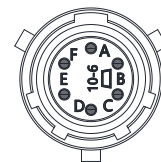
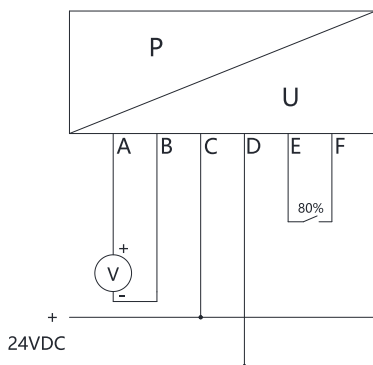

PIN	Function	Wire Color
A	Signal+	Red
B	Signal-	Black
C	Power+	White
D	Power-	Green
E	80%+	Blue
F	80%-	Orange

*B and D pins are connected internally

The cable shall be covered with shielding layer cable, each core wire is about 0.3 mm², temperature-resistance is not less than 105°C, each core wire connection column shall be insulated and protected by heat shrink tube isolation, shield wire shall be connected with plug-in metal, cable welding should be particularly careful, other wise it may lead to signal transmission error or damage products, it is recommended to use Ziasiot welded special cable. For excess lines in the cable, each wire should be wrapped separately with insulating tape.

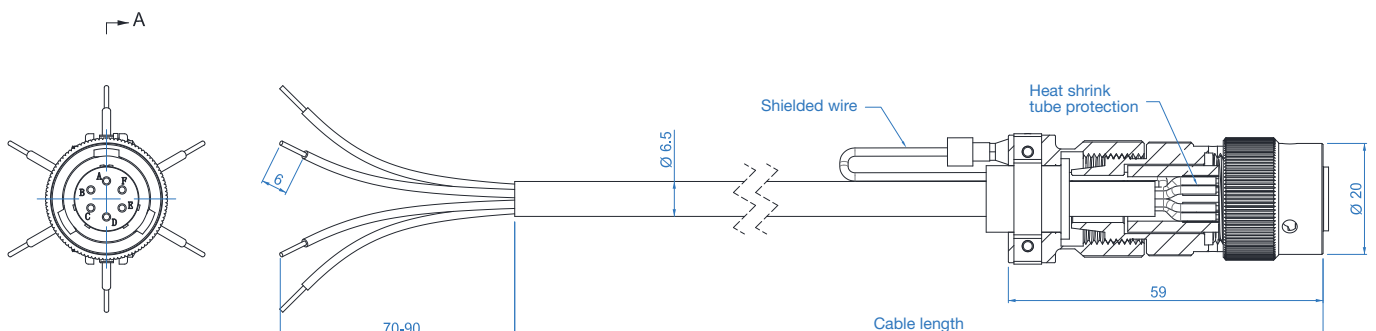

VIEW A-A

Ordering guide

Serie No	PT	X	-	X	-	X	-	X	-	X	-	X	-	X	-	X	-	X
Product type	Rigid Stem	170																
	Rigid+flexible stem	172																
	With thermocouple	173																
Pressure range	3.5MPa 35bar 500psi			5C														
	10MPa 100bar 1500psi			1.5M														
	20MPa 200bar 3000psi			3M														
	35MPa 350bar 5000psi			5M														
	50MPa 500bar 7500psi			7.5M														
	70MPa 700bar 10000psi			10M														
	100MPa 1000bar 15000psi			15M														
	200MPa 2000bar 30000psi			30M														
Process connection	1/2-20UNF					1/2												
	M14×1.5					M14												
	M18×1.5					M18												
Rigid stem length	6inch (152mm)							6										
	9inch (229mm)							9										
	12.5inch (318mm)							12										
	15inch (381mm)							15										
	18inch (460mm)							18										
Flexible stem length	18inch (460mm)								/18									
	24inch (600mm)								/24									
	30inch (760mm)								/30									
Output signal	4~20mA(Auto zero)									MA								
	4~20mA(One key to reset zero)									KA								
	0~10Vdc(Auto zero)									10V								
	0~10Vdc(One key to reset zero)									KV								
	3.33mV/V									MV								
E-connection	6-pin aviation Connector (p/n PT02A-10-6P)																	
	8-pin aviation Connector (p/n PT02A-10-8P)																	
Thermocouple	J Type																J	
	K Type																K	
	E Type																E	
	Pt100																RTD1	
Accuracy	0.50%																	--
	0.25%																	2A
Diaphragm	17-4PH (Standard)																	--
	inconel718 (anti-abrasive)																	I7
	C276 (Anti-corrosive)																	C2

Installation & Removal

Installation

When installing the pressure sensor, the sensor hole should be within the size requirement marked in following drawing and the assembly accuracy can be checked by testing bolts. Before installing the sensor, first clean the impurities in the hole and between the threads, then the thread of the sensor is coated with heat-resistant slurry, the screw teeth can be avoided. The installation force is very important, the installation torque of the sensor can only act on the shaft (hexagon), do not apply any force to the head of the sensor. The housing should be kept away from high temperature areas.

1/2-20 UNF /M14×1.5= Maximum starting torque: 40Nm

M18 x 1.5 = Maximum starting torque: 50 Nm

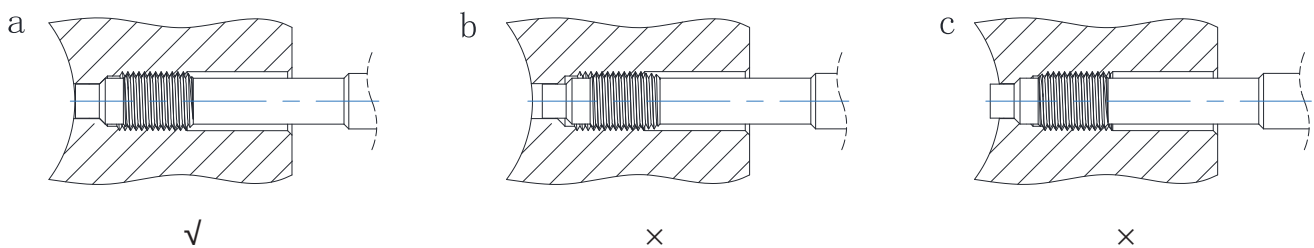

Removal

The removal of the pressure sensor (transmitter) must be done under heating conditions (plastic melting point). When removing the sensor (transmitter), note that the diaphragm has no contact pressure. The force to unload the sensor (transmitter) must be applied on the shaft (hexagon), and do not apply any force to the head of the sensor (transmitter).

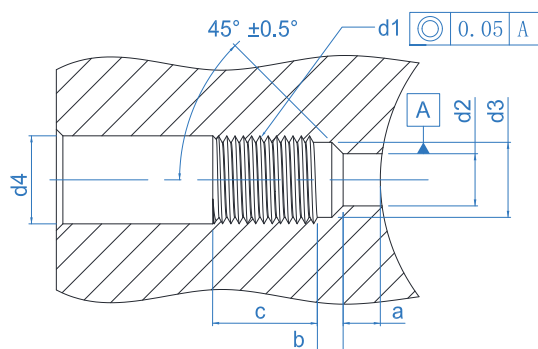

d1	M18×1.5	M14×1.5	1/2-20UNF-2A
d2	∅ 9.9 ^{+0.1}	∅ 7.9 ^{+0.1}	∅ 7.9 ^{+0.1}
d3	∅ 16.1 ^{+0.1}	∅ 11.7 ^{+0.1}	∅ 10.7 ^{+0.1}
d4	∅ 20	∅ 15	∅ 14
a	6.1 ^{-0.1}	5.7 ^{-0.1}	5.7 ^{-0.1}
b	4 ^{-0.2}	3.2 ^{-0.2}	3.2 ^{-0.2}
c	25	19	19

| Sensors cleaning

In order to clean the diaphragm, the sealing surface and thread of the transmitter must have the same temperature as the melting point of the plastic. The diaphragm and sealing surface can be cleaned with soft cloth, and rigid rod can be cleaned with steel brush or copper brush. (Do not touch diaphragm surface with the steel brush.)

| Transport and storage

PT170 / PT172 / PT173 Series melt pressure sensors (transmitters) are usually packaged separately. At the front thread of the rigid rod, the induction diaphragm is protected by a protective cap. This protective cap should be tightened at any time during storage, and only opened during installation.

Note: Mounting brackets, extension cables, connectors, cleaning kits, drill kits, dummy plug etc accessories, please contact with us.