

Instructions

Standard Melt Pressure Sensor

PT112/PT123/PT133 Series



attestation

ISO 9001:2015

Please read this instruction manual carefully before installation



Content

- 1.Introduction
- 2.Application
- 3.Product features
- 4.Technical data
- 5.Dimensions
- 6.Electrical connection and debugging
- 7.Ordering Guide
- 8.Installation and Removal
- 9.Sensors cleaning
- 10.Transport and storage

Introduction

PT112/PT123/PT133 melt pressure sensor is an accurate measuring equipment. The initial mV signal is compensated into standard 3.33 mV/V or 2.5 mV/V signal by using high quality core element. The measurement accuracy can be obtained by 0.5%.

Application

This series is designed for pipe extrusion, sheet extrusion, recycled plastics, recycled plastics and other extrusion processes with simple control.

Product features

- Accuracy 0.5%FS
- Stainless steel sealing
- 80% internal calibration
- Good stability and repeatability

Technical data

Pressure Range	0~35bar ; 0~2000bar
Accuracy	±0.5%
Over load Pressure	1.5FSO
Bridge Resistance	350Ω Wheatstone bridge
Power	6-12Vdc(10Vdc Standard)
Output Signal	3.33mV/V
Load Resistance (Ω)	>10k
Calibration	80%FSO
Process Connection	M14×1.5 , 1/2UNF , M22×1.5
Insulation Resistance(50Vdc)	1000MΩ
Diaphragm Material	17-4PH , inconel718 , C276
Diaphragm Max Temp	400°C
Film Material	TiAIN
E-connection	6-pin connector(Standard) , 8-pin connector
Electrical Environment Temp	-20°C~85°C
Thermocouple	J Type , E Type , K Type , pt100
Protection Degree	IP65
Installation Torque	<30Nm
Filing Material	Mercury filing

Dimensions

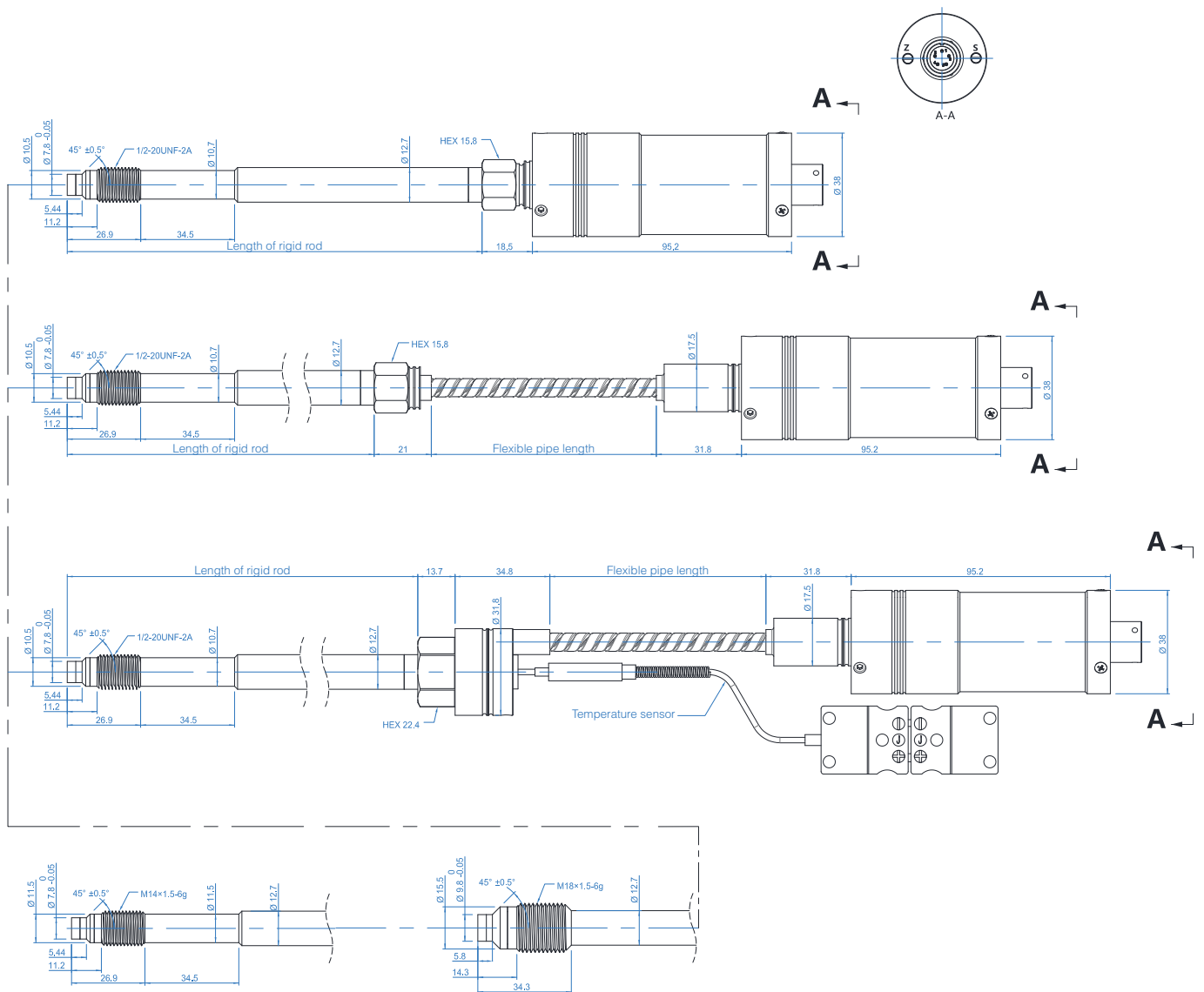

Electrical connection & Debugging

After the pressure sensor has been installed on the pipeline, the electrical connection must be carried out in accordance with the connection the wiring diagram below.

PT112/PT123/PT133 pressure sensor internal compensation has 80% calibration function, the calibration process must be pipeline heating and pressure is zero. Connect the calibration line to the negative pole of the excitation power supply (see wiring diagram), and the pressure sensor will provide a signal of standard 80% measurement.

3.33mV/V (4-wire)

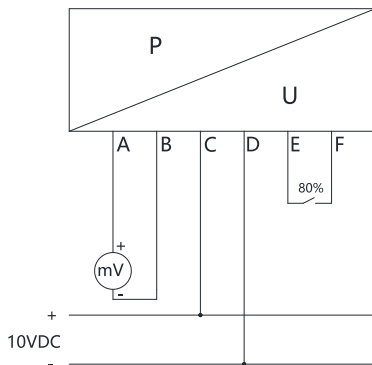

6-pin connector /PT02A-10-6P

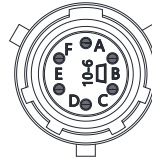

PIN	Function	Wire Color
A	Signal+	Red
B	Signal-	Black
C	Power+	White
D	Power-	Green
E	80%+	Blue
F	80%-	Orange

3.33mV/V (4-wire)

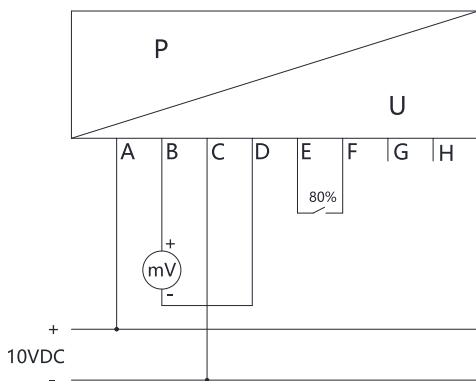

8-pin connector /PT02A-10-8P

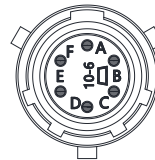

PIN	Function	Wire Color
A	Power+	Red
B	Signal-	Black
C	Power+	White
D	Signal-	Green
E	80%+	Blue
F	80%-	Yellow
G		Grey
H		Brown

The cable shall be covered with shielding layer cable, each core wire is about 0.3 mm², temperature-resistance is not less than 105°C, each core wire connection column shall be insulated and protected by heat shrink tube isolation, shield wire shall be connected with plug-in metal, cable welding should be particularly careful, otherwise it may lead to signal transmission error or damage products, It is recommended to use Ziasiot welded special cable. For excess lines in the cable, each wire should be wrapped separately with insulating tape.

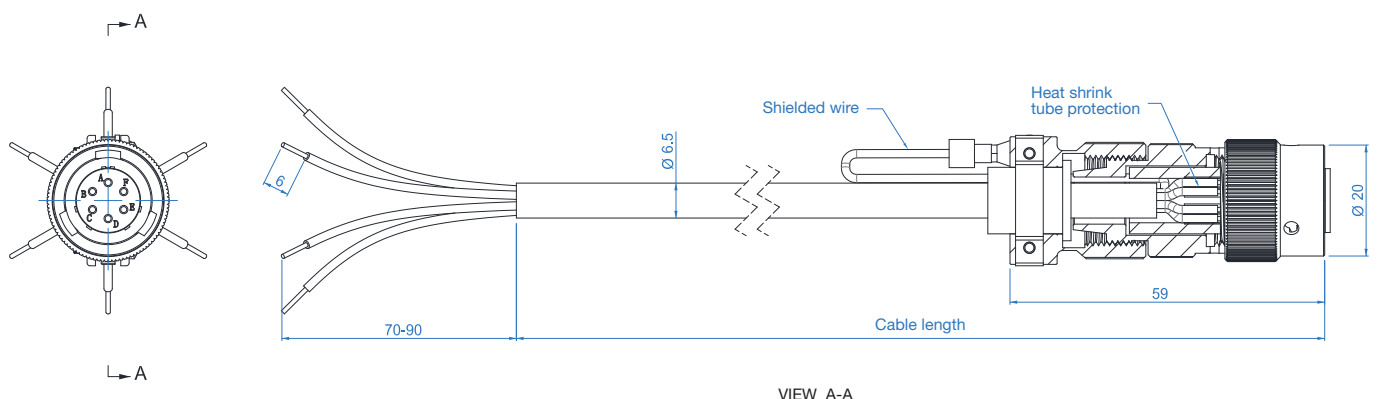

Ordering guide

Serie No	PT	X	-	X	-	X	-	X	-	X	-	X	-	X	-	X	-	X
Product type	Rigid Stem	112																
	Rigid+flexible stem	123																
	With thermocouple	133																
Pressure range	10MPa 100bar 1500psi			1.5M														
	20MPa 200bar 3000psi			3M														
	35MPa 350bar 5000psi			5M														
	50MPa 500bar 7500psi			7.5M														
	70MPa 700bar 10000psi			10M														
	100MPa 1000bar 15000psi			15M														
	200MPa 2000bar 30000psi			30M														
Process connection	1/2-20UNF					1/2												
	M14×1.5					M14												
	M18×1.5					M18												
Rigid stem length	6inch (152mm) (6F Standard length)							6										
	9inch (229mm)							9										
	12.5inch (318mm)							12										
	15inch (381mm)							15										
	18inch (460mm)							18										
Flexible stem length	18inch (460mm)							/18										
	24inch (600mm)							/24										
	30inch (760mm)							/30										
Output signal	3.33mV/V							--										
	2.5mV/V							2.5MV										
E-connection	6-pin aviation Connector (PT02A-10-6P)													--				
	8-pin aviation Connector (PT02A-10-10P)													8P				
Thermocouple	J Type													J				
	K Type													K				
	E Type													E				
	Pt100													RTD1				
Accuracy	0.50%															--		
	0.25%															2A		
Diaphragm	17-4PH (Standard)																--	
	inconel718 (anti-abrasive)																17	
	C276 (Anti-corrosive)																C2	

Installation & Removal

Installation

When installing the pressure sensor, the sensor hole should be within the size requirement marked in following drawing and the assembly accuracy can be checked by testing bolts. Before installing the sensor, first clean the impurities in the hole and between the threads, then the thread of the sensor is coated with heat-resistant slurry, the screw teeth can be avoided. The installation force is very important, the installation torque of the sensor can only act on the shaft (hexagon), do not apply any force to the head of the sensor. The housing should be kept away from high temperature areas.

1/2-20 UNF /M14×1.5= Maximum starting torque: 40Nm

M18 x 1.5 = Maximum starting torque: 50 Nm

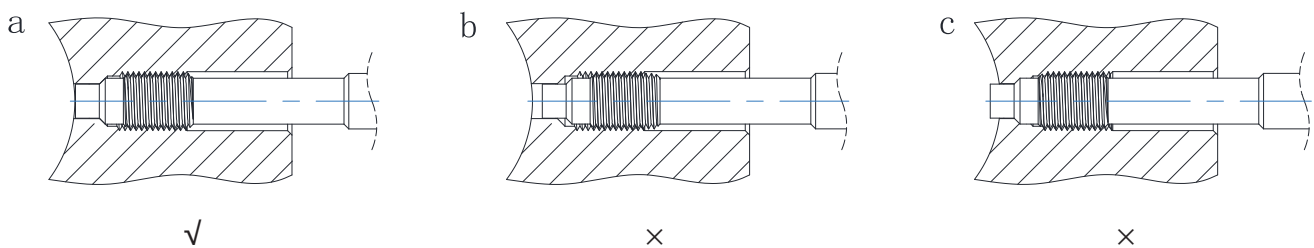

Removal

The removal of sensor must be done under heated conditions (plastic melting point). When removing the sensor, please note that the diaphragm has no contact pressure. The force to unload the sensor must be applied on the shaft (hexagon), and do not apply any force to the head of the sensor.

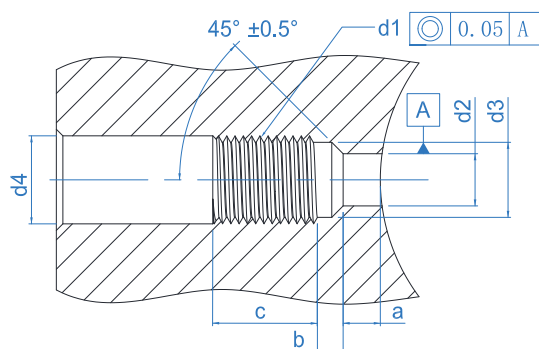

d1	M18×1.5	M14×1.5	1/2-20UNF-2A
d2	∅ 9.9 ^{+0.1}	∅ 7.9 ^{+0.1}	∅ 7.9 ^{+0.1}
d3	∅ 16.1 ^{+0.1}	∅ 11.7 ^{+0.1}	∅ 10.7 ^{+0.1}
d4	∅ 20	∅ 15	∅ 14
a	6.1 ^{-0.1}	5.7 ^{-0.1}	5.7 ^{-0.1}
b	4 ^{-0.2}	3.2 ^{-0.2}	3.2 ^{-0.2}
c	25	19	19

| Sensors cleaning

In order to clean the diaphragm, the sealing surface and thread of the sensor must have the same temperature as the melting point of the plastic. Both the diaphragm and the sealing surface can be wiped clean with a soft cloth, and the thread can be cleaned with a steel brush or a copper brush.

(Do not touch the surface of the diaphragm with the steel brush)

| Transport and storage

PT112/PT123/PT133 pressure sensor is usually packed separately. At the front thread of the rigid rod, the induction diaphragm is protected by a protective cap. This protective cap should be tightened at any time during storage, and only opened during installation.

Note: Mounting brackets, extension cables, connectors, cleaning kits, drill kits, dummy plug etc accessories, please contact with us.