

Instructions

77-81GHz Continuous FM Wave Radar Bit Meter



Content

1. INTRODUCTION

- 1.1 Application function
- 1.2 RD800X Products suitable for the application field
- 1.3 RD800X Product features

2. SPECIFICATIONS

3. INSTALL

- 3.1 Installation site
- 3.2 Installation angle

4. DIMENSIONS

5. CONNECTION

- 5.1 Product power supply wiring diagram
 - 5.1.1 Wiring diagram of 24VDC
 - 5.1.2 Two-wire manufacturing product wiring diagram
- 5.2 24 Description of the VDC power supply product interface

6. OPERATION

- 6.1 Key instructions
- 6.2 Description of the running measurement interface
- 6.3 Description of the echo-curve interface
- 6.4 Description of the setting parameter interface
 - 6.4.1 [Basic settings]
 - 6.4.2 [Display]
 - 6.4.3 [Diagnostic]
 - 6.4.4 [Service]
 - 6.4.5 [Information]
- 6.5 Menu options action settings
 - 6.5.1 Basic settings menu operations
 - 6.5.1.1. [Application type]
 - 6.5.1.2. [Container type]
 - 6.5.1.3. [Media type / Dielectric constant]
 - 6.5.1.4. [Low adjustment]
 - 6.5.1.5. [High adjustment]
 - 6.5.1.6. [blind area setting]
 - 6.5.1.7. [Scale setting]
 - 6.5.1.8. [Damping period]
 - 6.5.1.9. [Sensor mode]

- 6.5.2 Displays the menu operation
 - 6.5.2.1. [Parasang]
 - 6.5.2.2. [Degree-day]
 - 6.5.2.3. [Display language]
- 6.5.3 Diagnostic menu operation
 - 6.5.3.1. [Evolution curve]
 - 6.5.3.2. [Historical curve]
 - 6.5.3.3. [Historical time]
 - 6.5.3.4. [Historical measurement peak value]
 - 6.5.3.5. [Historical temperature peak]
 - 6.5.3.6. [Historical feed rate]
 - 6.5.3.7. [Historical discharge rate]
- 6.5.4 Service menu operation
 - 6.5.4.1. [False-echo learning]
 - 6.5.4.2. [Restore factory]
 - 6.5.4.3. [Rate of feed]
 - 6.5.4.4. [Discharge rate]
 - 6.5.4.5. [Current simulation]
 - 6.5.4.6. [4 mA position]
 - 6.5.4.7. [20 mA position]
 - 6.5.4.8. [Current-output function]
 - 6.5.4.9. [Bus address]
 - 6.5.4.10. [Distance offset]
 - 6.5.4.11. [Fault output current]
 - 6.5.4.12. [Fault timer]
- 6.5.5 Information menu operations
 - 6.5.5.1. [Sensor model]
 - 6.5.5.2. [Sensor label]

6.6 Keyboard menu editing operation

7. Glossary

1. INTRODUCTION

1.1 Application function

RD800X77-81GHz FM FMCW radar products (also known as millimeter wave radar), because it adopts higher than Ku band radar frequency millimeter wave band, in the remote target detection, strong smoke dust environment, long distance imaging, multispectral imaging has important applications, and can detect smaller than microwave radar and achieve more accurate positioning, with higher resolution and stronger confidentiality.

What is millimeter wave electromagnetic wave: usually 30-300GHz frequency domain (wavelength is 1~10 mm) electromagnetic wave called millimeter wave, it is located in the microwave and far infrared wave overlapping wavelength range, so it has the characteristics of two spectra. The 77-81GHz band of this product is the least understood and developed region, with the following features.

- Good transient performance: the pulse width of this band can be narrow in sub-picosecond (ps) level, so it can be used for time-resolved study of various materials, measuring the molecular structure; through the sampling measurement technology, can effectively suppress the interference of far red background noise.
- There is a very wide broadband: this band pulse source usually only needs a few cycles of electromagnetic wave shock, and many biological macromolecular vibration and rotational energy level, dielectric, semiconductor, superconducting, thin film material molecular vibration level of the band close to. Therefore, this band spectrum can be used as an effective means to detect the material information in the millimeter wave band, which is very suitable for measuring the material absorption spectrum, and can be used for qualitative identification applications.
- Coherence: dipole oscillation driven by coherent current or nonlinear differential frequency effect of coherent laser pulse;
- Low energy: millimeter wave photon energy is only a few millielectron volt, there will be no X-ray ionization and destruction of the substance to be detected, so it is not easy to destroy the substance to be detected.
- Strong penetration: with a strong penetration force for nonpolar substances, many non-metallic nonpolar materials have little ray absorption of this band, so it can be used to detect the internal structure of the material. For example, ceramics / cardboard / plastic products / foam are transparent to this band electromagnetic radiation, and can also be used for airport / station safety monitoring, such as exploring machinery / explosives and drugs, or for circuit board welding detection.

- Easy to be absorbed by polar molecules: this band has less scattering in the non-uniform substances, and can detect and measure the water vapor content. They can also be studied by analyzing their characteristic profiles or by conducting quality control.

As a 78GHz band radar used in the field of industrial measurement, high precision and non-contact level and liquid level measurement has the incomparable advantages of other ordinary microwave pulse radar and guided wave radar. Its extremely narrow beam and penetration ability can be more adapt to super complex working conditions without weakening the measurement performance.

1.2 RD800X Products suitable for the application field

- The product electromagnetic wave emission angle is less than 3°, which is suitable for narrow space or guide wave pipeline measurement
- The product can reach a 120M measurement range, suitable for the measurement of a very large storage tank
- Product measurement blind area in 7-8CM range, suitable for small storage tanks
- The product has extremely high measurement accuracy, suitable for high precision measurement
- The product has rich echo processing algorithm and experience data of various operating conditions, mixing and heating rod.

1.3 RD800X Product features

- 77GHz-81GHz FM wave radar
- 5GHz super-large FM scanning frequency width, wide application surface
- Standard HART, RS485 / MODBUS bus protocol is supported
- Support the upper machine setting software, tank side table and other operating modes
- 24VDC power supply
- Simple installation structure, adapted to various installation forms on site

2. SPECIFICATIONS

Emission frequency	77GHz~81GHz, with an FM scan frequency width of 5GHz
Measuring range	RD800X0:0.2 m~60m (solid) (0.2m in T0 series) RD800X1:0.0 m ~30m (liquid) (0.2m for T0 series) RD800X2:0.6m~120m (solid) (blind area increased by 0.2m in T0 series)
Certainty of measurement	±1mm
Beam angle	3° , 8°
Dielectric constant range was used	≥2
Power supply range	18~28.0VDC , 220VAC RD800X2:4 lines of the system RD800X3x: 2-wire system
Communication mode	RD800X2x: MODBUS bus RD800X3x: HART
Signal output	RD800X: 4 to 20 mA or RS-485 RD800X: 4~20mA
Failure output	3.8 mA, 4 mA, 20 mA, 21 mA, and maintained
Field operation / programming	12864 Dot array display / 4 buttons The upper computer setting software can be configured
Industrial temperature / humidity	-40~85°C / ≤95%RH
Case material	Aluminum alloy, stainless steel
Antenna type	Lens antenna, equipped with lens antenna shield / anticorrosive antenna / antenna radiator paste / quartz isolation flange plate
Process pressure	-0.1~2MPa
Product size	Ø 100*270mm
Cable inlet	M 20*1.5
Recommended cable	AWG 18 or 0.75mm ²
Levels of protection	IP67
Anti-hazard classification	Exd i b II B T6 Gb
Way to install	Threaded or flange
Net weight / gross weight	2.480Kg/2.995Kg
Box size	300*300*600mm

3. INSTALL

3.1 Installation site

- Avoid mounting the instrument in the central position or near the edge of the container, otherwise likely to produce incorrect readings.

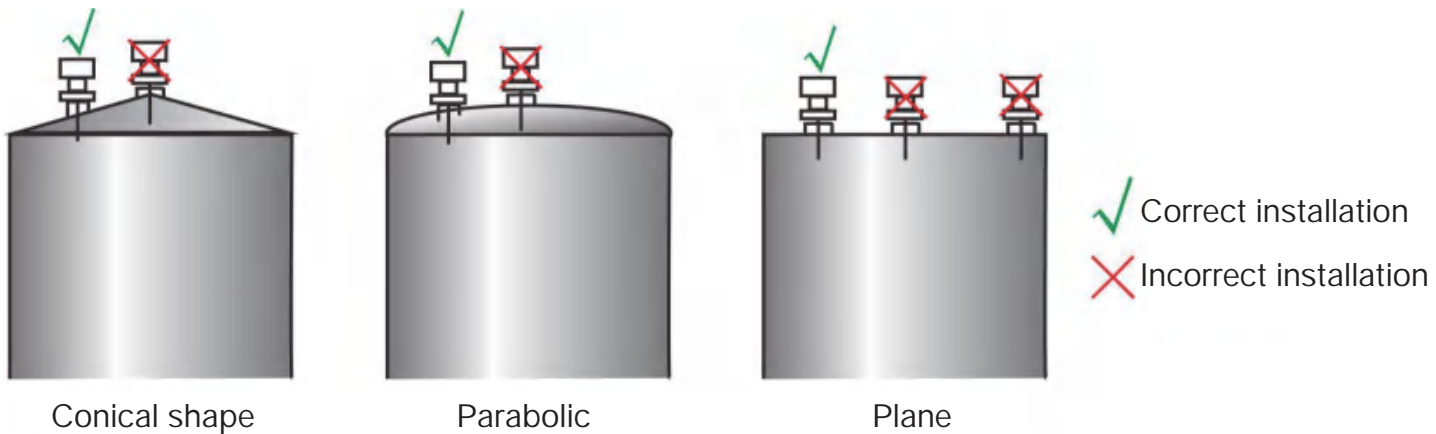

Figure 3-1 Schematic diagram of the instrument installation position

- Example of avoiding spurious echoes

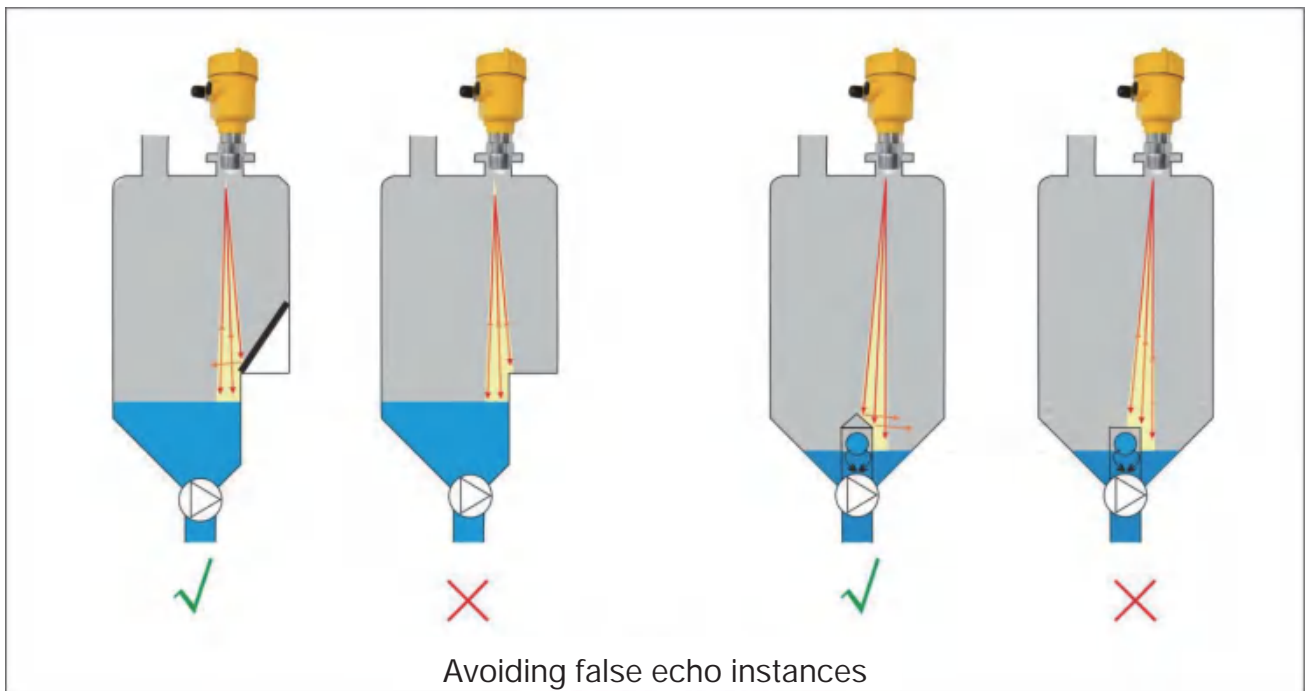

Figure 3-2 Schematic representation of avoiding false echoes

- Ladder position and grille tank treatment

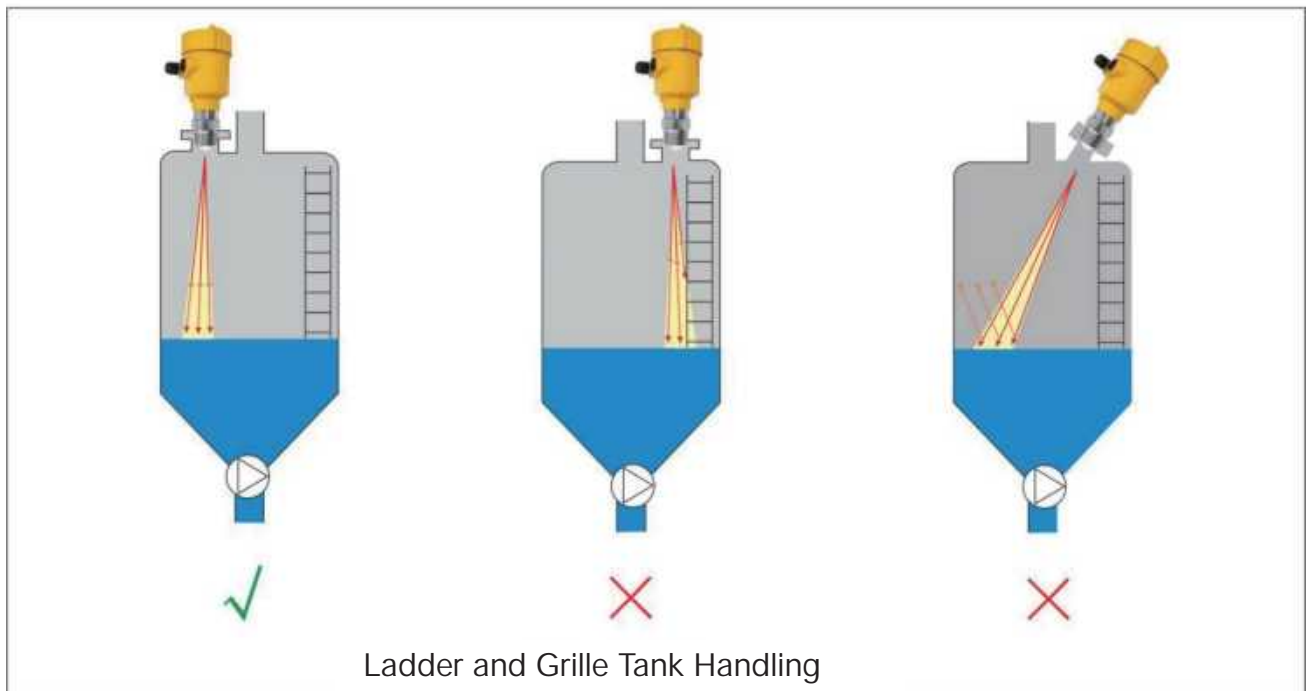

Figure 3-3 Ladder and grille tank treatment

- Wall hanging and grille tank treatment

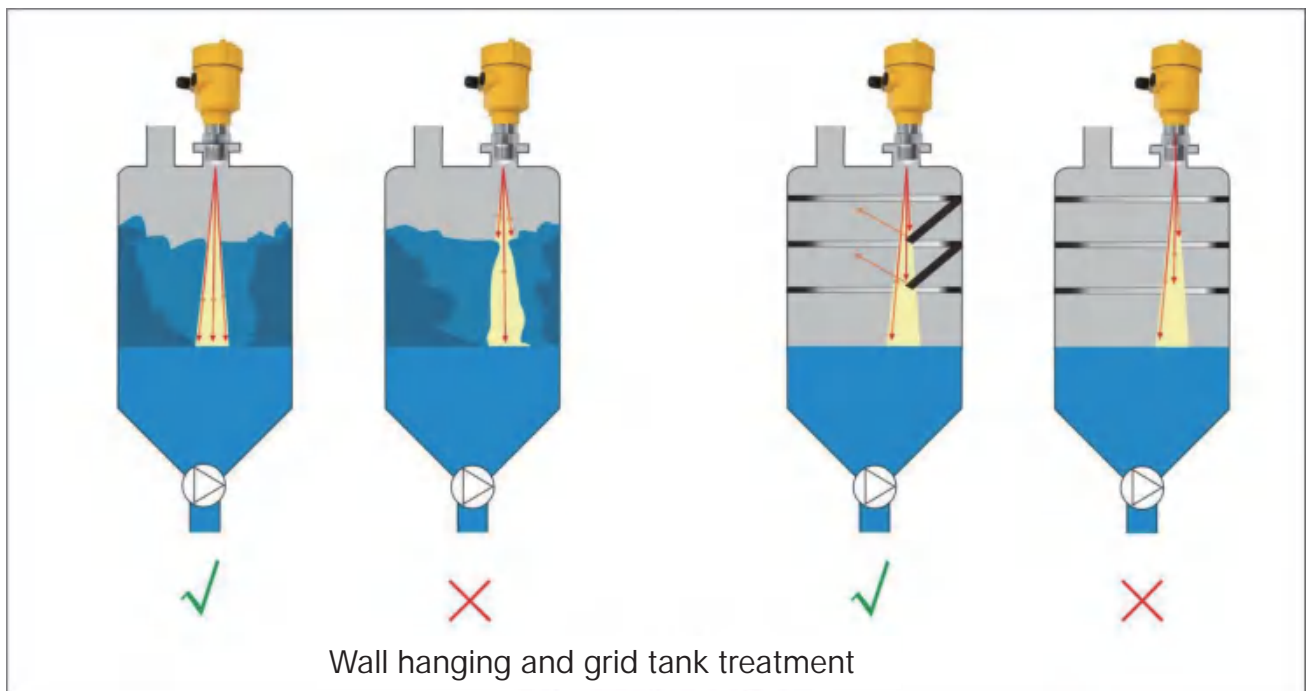

Figure 3-4 Hanging wall and grille tank treatment

3.2 Installation angle

- Beam scattering: due to the polarization effect of microwave signal and the vessel wall, the instrument distance from the container shall be no less than 20mm from the side wall.
- Polarization effect:
 - (1) Emission cones encountering flat obstacles and vertical struts can cause large spurious reflections. These obstacles reflect radar signals of large amplitude. The surface of circular obstacle scatters the reflected wave of radar signal, produces false reflection of small amplitude.
 - (2) To obtain the minimum false reflection, the instrument is first rotated to obtain the best signal (the lowest false echo amplitude), and then the false echo curve is established.

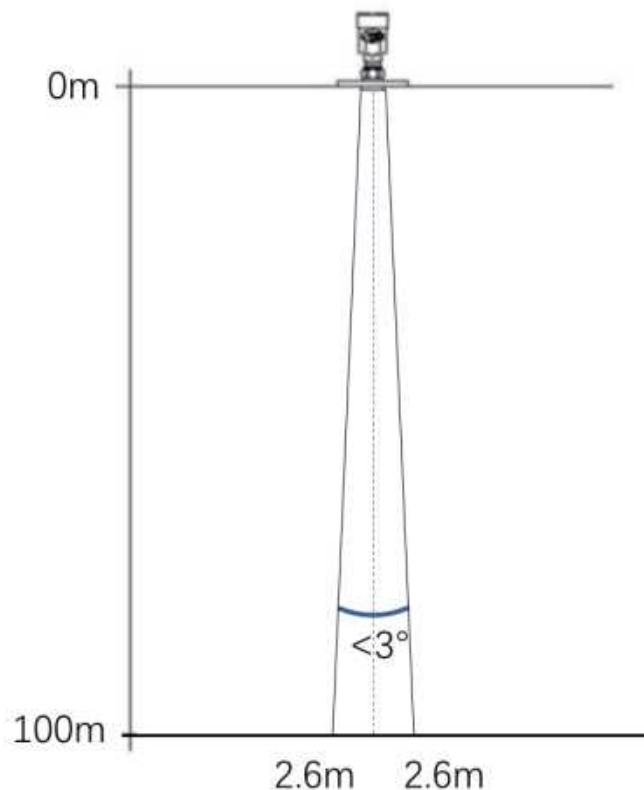

Figure 3-5 Schematic diagram of the radar beam space geometry of the instrument

- FM resolution
RD800X Frequency modulation bandwidth of $B=5.1\text{GHz}$, the minimum distance resolution

$$S_{\text{res}} = \frac{C}{2 \times B} = 29.25\text{m}$$

The IF signal of RD800X was analyzed by its own algorithm with a measurement accuracy of 0.1mm.

- Distance resolution (Range Resolution)

Generally speaking, distance resolution refers to how far two objects are apart, and the bit radar can distinguish two objects rather than one and measure their respective distances.

If the distance interval between two objects is less than the distance resolution of the object radar, then the radar can only measure a distance value, which is not equal to the distance value of either of the objects, but a combination of the distance values of the two objects.

- Measurement accuracy (Accuracy)

If there is only one object and the object moves for a small distance, whether the position radar can recognize the distance change. The indicator that determines the movement distance of an individual object is called precision.

4. DIMENSIONS

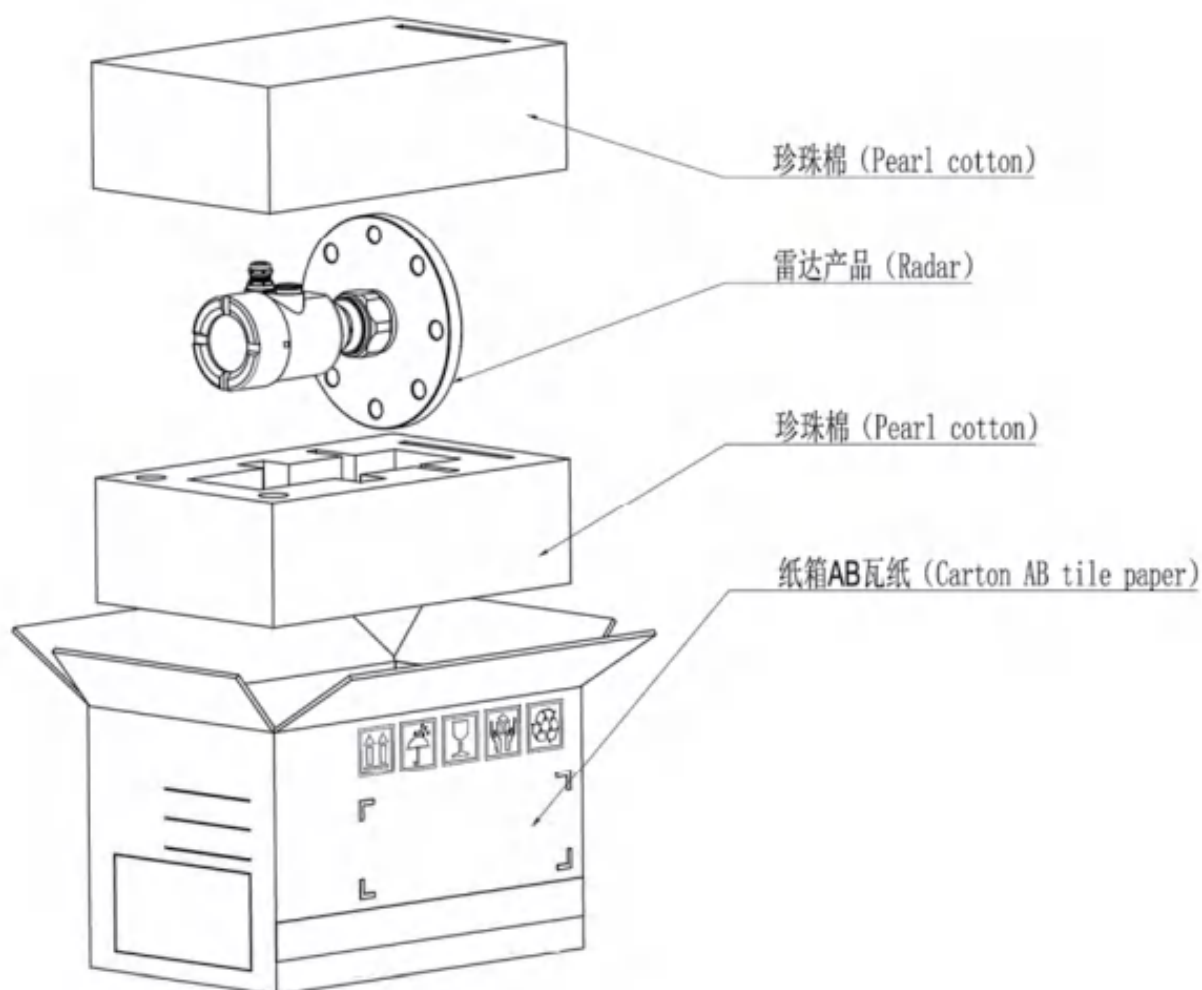
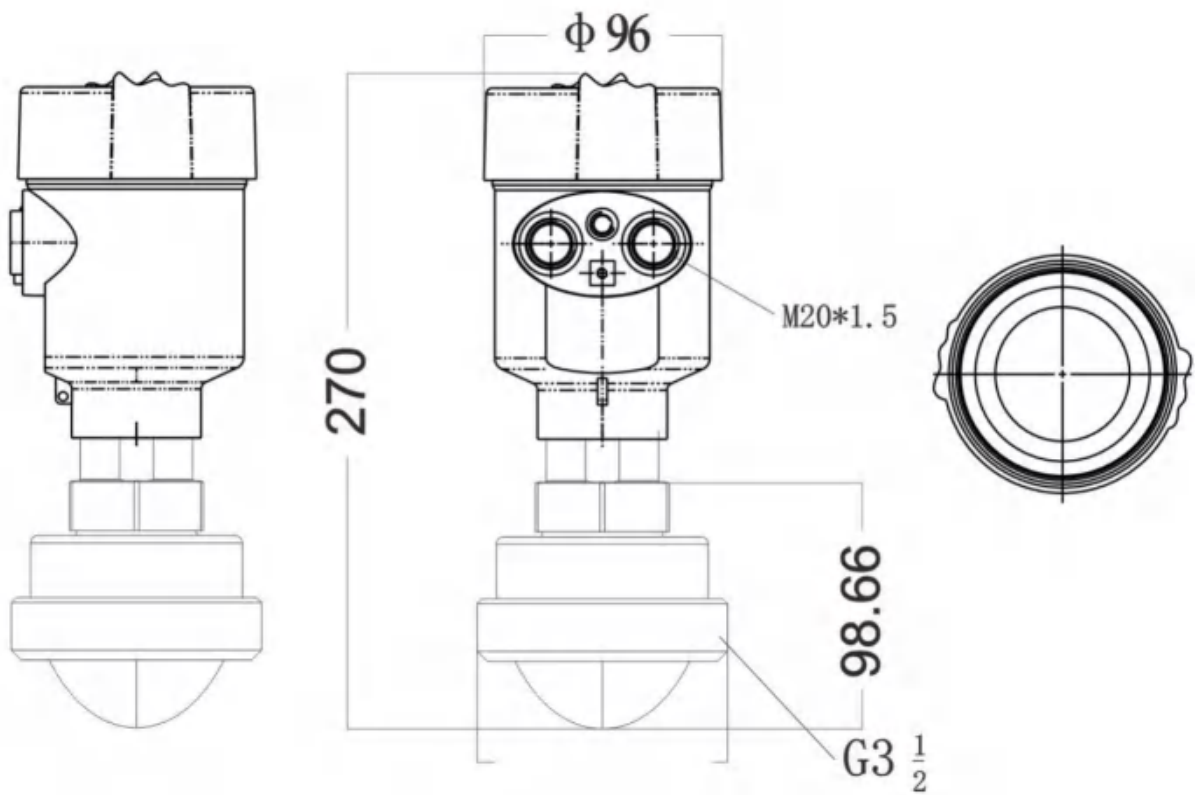

Figure 4-1 Diagram of instrument packaging

3deg overall appearance



8deg overall appearance

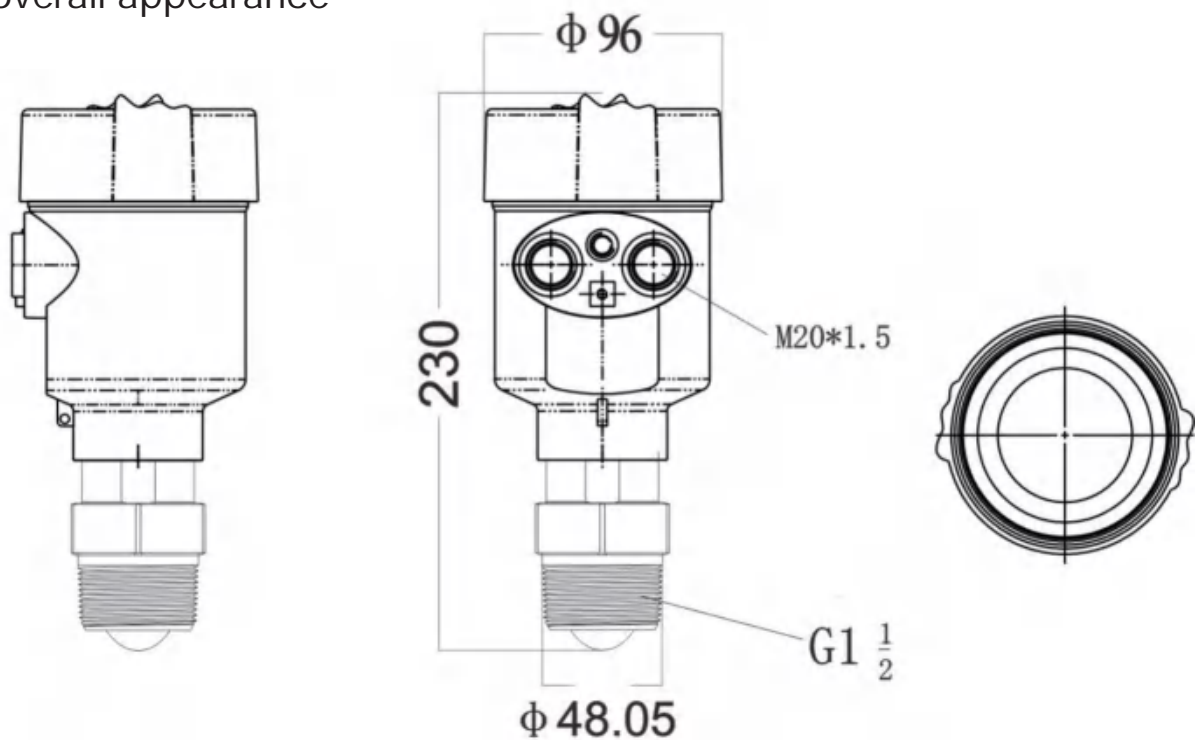
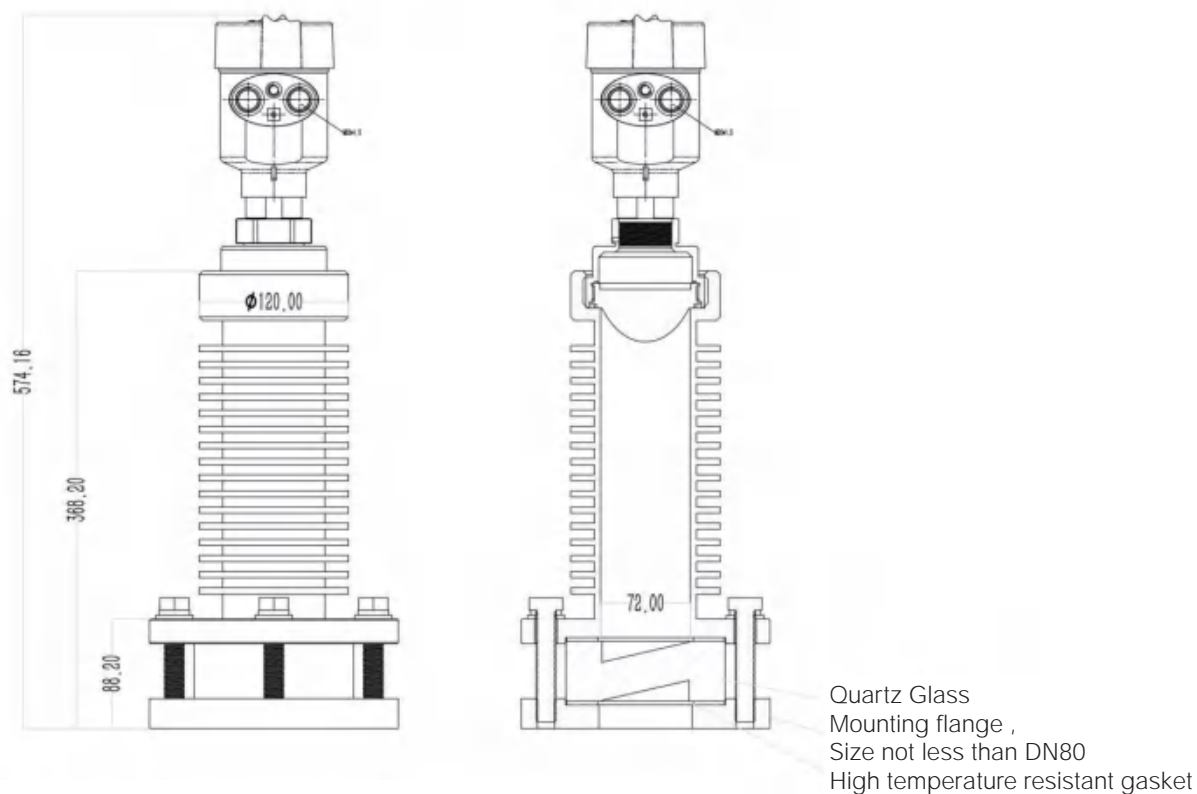

Figure 4-2 Dimdiagram of instrument structure

Equipped with high-temperature flange 3deg overall appearance



Equipped with high-temperature flange 8deg overall appearance

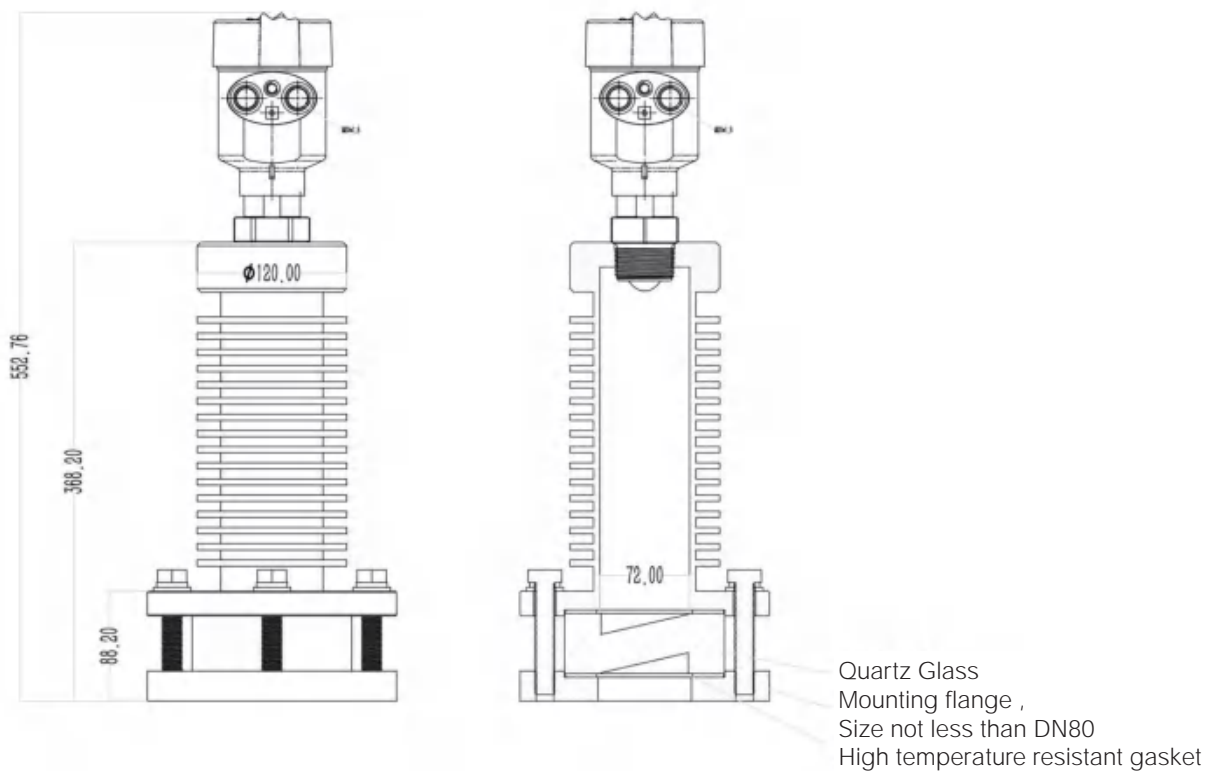

Figure 4-3 Schematic diagram of the high-temperature structure

5. CONNECTION

5.1 Product power supply wiring diagram

5.1.1 Single chamber shell 24VDC power supply four-wire system, product wiring diagram

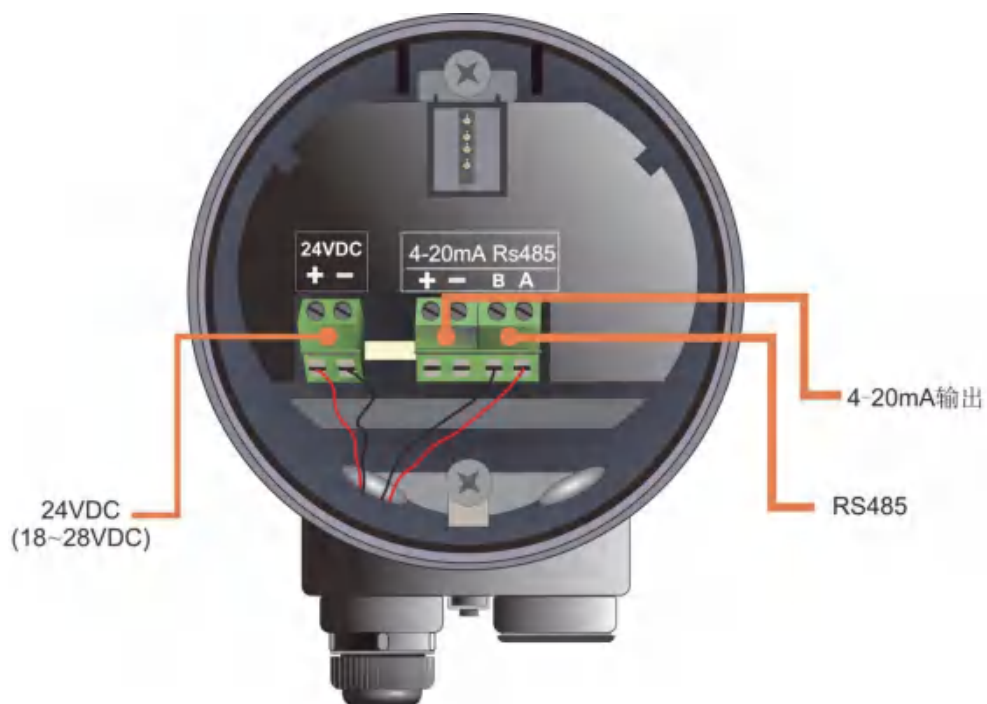

Figure 5-1 Single chamber housing 24VDC product wiring diagram

5.1.2 Two-wire manufacturing product wiring diagram

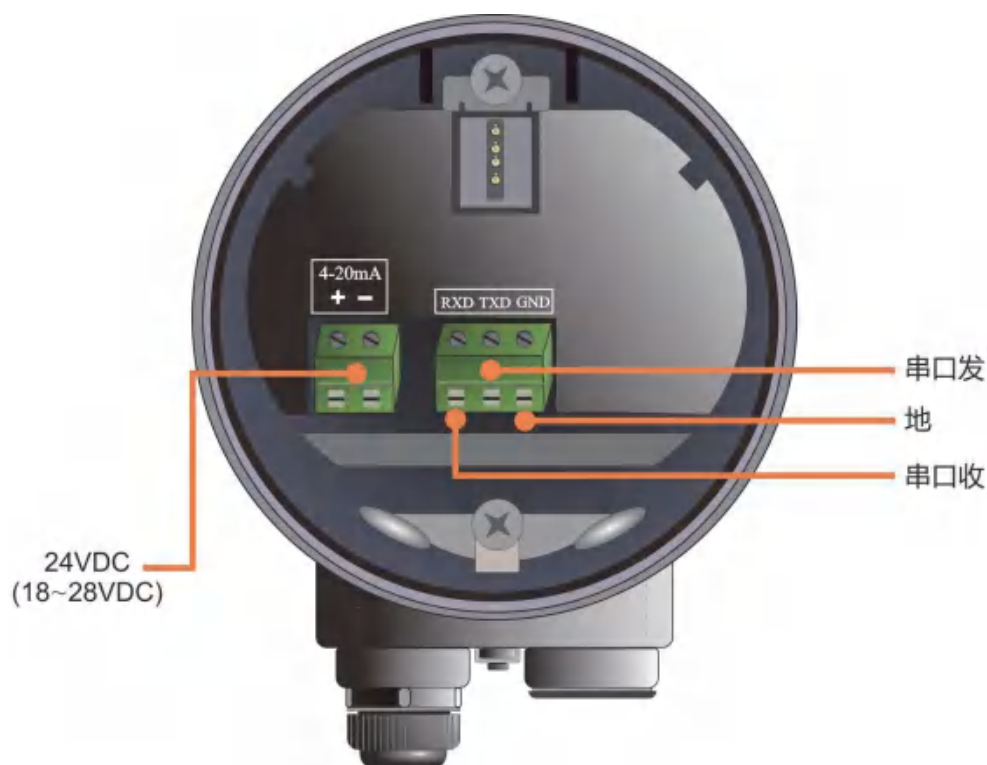

Figure 5-2 Wiring diagram of two-wire manufactured products

5.2 24 Description of the VDC power supply product interface

Table 5-1 Description of interface of four-line product

PIN1	24VDC (+) power cord positive end
PIN2	24 The minus end of the VDC (-) power line
PIN3	4-20 mA (+), 4-20 mA current output plus end
PIN4	4-20 mA (-), 4-20 mA current output minus end
PIN5	RS485 (A), 485 communication output
PIN6	RS485 (B), 485 communication outputs

Table 5-2 Description of interface of two-line products

PIN1	4-20 mA (+), 4-20 mA current plus end
PIN2	4-20 mA (-), 4-20 mA current minus end
PIN3	RXD, serial port receiving
PIN4	TXD, the serial port is sent
PIN5	GND, the earth

6. OPERATION

6.1 Key instructions

The product display module is displayed by 4 buttons and a 12864 dot array display.

The display system has 4 display interface modes:

- [Operation measurement interface Run Mode]: Display the system running state and the current measurement data
- [Echo curve interface Echo Mode]: displays the current echo situation measured by the system
- [History curve interface Memo Mode]: displays the historical measurement data of the system operation records
- [Set the parameter interface Setup Mode]: Set all kinds of data parameters for the system operation
- [Input data interface Input Mode]: Enter the value, number or character of the parameter

The functions of the four buttons are also different in different display modes

6.2 Description of the running measurement interface

Table 6-1 Description of the key function when running the measurement interface

Tagging	Function	Fingerboard	Explain
1	-Switch into the setting parameter interface	OK	
2	-NULL	UP(↑)	
3	-NULL	DN(↓)	
4	-Switch into the echo curve interface	BK	

- Run the measurement interface, displayed as shown below.
- The largest number represents the measured damping value, the damping value below the number of measurement no damping value, other display the digital resolution analog output conversion value (RD800X product in 4-20 mA output is not connected, there is no 4-20 mA output, but does not affect the corresponding conversion value), ambient temperature value, product model, and fault code.



Figure 6-1 Schematic diagram of the running measurement interface

6.3 Description of the echo-curve interface

Table 6-2

Tagging	Function	Fingerboard	Explain
1	-Switch into the Run measurement interface	BK	
2	-NULL	UP(↑)	
3	-Show / hide the threshold curve	DN(↓)	
4	-NULL	OK	

- Under the running measurement interface, press [BK] to enter the echo curve interface



Figure 6-2 Schematic diagram of the echo curve interface

In the echo interface, the top line from left to right is: echo strength (against the better metal plate, the strength should be above 400), measure the no damping value, and measure the damping value.

- In the echo curve interface, press [DN (↓)] to switch the display / hide of the TVT curve.



Figure 6-3 Echo curve interface shows the schematic diagram of the TVT curve

- At the echo curve interface, pressing [BK] can switch the echo curve interface to the running measurement interface.

6.4 Description of the setting parameter interface

Table 6-3 Functional description of the keys when setting the parameter interface

Tagging	Function	Fingerboard	Explain
1	-Switch into the Run measurement interface	BK	
2	-Move up to select the entries	UP(↑)	
3	-Move down to select the entry	DN(↓)	
4	-Enter the selected entry subinterface	OK	

- From the running measurement interface, press [OK] to enter the setting parameter interface, as shown in the following figure:



Figure 6-4 Setting the parameter interface (1)

6.4.1 [Basic Settings]

[Basic Settings] Menu items can realize various functions, as shown in the table below. With these parameter settings, a rapid start of the bit meter can be implemented.

Select [Basic Settings] and press [OK] to enter the options interface. The options list is shown in the following table:

Table 6-4 Basic settings menu options

Default location	Menu item
•	Application type
	Container type
	Media type
	High and low position adjustment
	Blind area setting
	Range setting
	Damping period
	Sensor mode

6.4.2 [Display]

[Display] menu items can realize [distance unit], [temperature unit] and [display language] switching and [LCD contrast].

Select [Display] and press [OK] to enter the options interface. The options list is shown in the following table:

Table 6-5 shows the menu options

Default location	Parent menu item	menu item
•	Parasang	m , cm , mm , ft , in
	Degree-day	°C , K
	Display language	Chinese, English
	LCD contrast ratio	Value high screen color heavy Small value screen with light color

6.4.3 [Diagnostic]

[Diagnostic] menu items can realize the statistics of current and historical data, summarize the working condition and field environment.

Select [Diagnostic], and enter the option interface by pressing [OK]. The list of options is shown in the following table:

Table 6-6 Diagnostics menu options

Default location	Menu item
•	The echo curve
	False echo curve
	Historical curve
	Historical time
	Peak historical temperature
	Historical feed rate
	Historical feeding rate

6.4.4 [Service]

Select [Service] and press [OK] to enter the options interface. The options list is shown in the following table:

Table 6-7 Professional Settings menu Options

Default location	Menu item
•	False echo learning
	Restore factory
	In and outgoing rate
	Current simulation
	The 4 mA \ 20 mA position

	Current output function
	Bus address
	Distance offset
	Fault output current
	Fault timer
	Parameter backup

6.4.5 [Information]

Select [Information] and press [OK] to enter the option interface. The [Information] menu has the following options, as shown in the following table:

Table 6-8 Information menu options

Default location	Menu item
•	Sensor model
	Serial number
	Sensor label

6.5 Menu options action settings

6.5.1 Basic settings menu operations

When the instrument is charged, the display enters the operation measurement interface, press [OK] key and enter the [Basic Settings] menu, as shown in the figure below, select [Basic Settings] and press [OK] button to enter the basic Setoptions interface.



Figure 6-5 Basic Settings menu interface

6.5.1.1. [Application Type]

Enter the [Basic Settings] menu, select the [Application Type], and press the [OK] button to enter the container type selection menu.

solid body
liquid

6.5.1.2. [Container Type]

Enter the [Basic Settings] menu, select [Container Type], press [OK] to enter the container type selection menu.

Table 6-9 Description of the container type

The parameter name	Container type		
	RD800X (Solid state)	RD800X (Solid state)	RD800X (Liquid)
Large volume storage	The inlet and outlet feed speed is adjusted to: 0.1m / min Tracking state		The feed and outlet speed is adjusted to 1m / min Tracking state
Medium volume storage	The feed and outlet speed is adjusted to 1m / min Tracking state		The feed and outlet speed is adjusted to 1m / min Tracking state
Fine and high material warehouse	Import and export speed is adjusted to 10m / min Tracking state		Import and export speed is adjusted to 10m / min Tracking state
Demonstrate	Non-tracking status The test location is centered		Non-tracking status

6.5.1.3. [Media type / Dielectric constant]

Enter the [Basic Settings] menu, select [Media Type / Dielectric constant], press [OK], enter the media type / dielectric constant menu.

Table 6-10 Description of the container type

	RD800X (Solid state)	RD800X (Solid state)	RD800X (Liquid)
The parameter name	Media type		Dielectric constant
Large volume storage	Powder lot		And a dielectric constant of > 10
Medium volume storage	Small pieces of solid		3-10
Fine and high material warehouse	Large solid		<3

6.5.1.4. [High-and low-level adjustment]

[Low-level adjustment] involves the range setting. It maps the measurement to the current output (4-20 mA).[Basic Setting] Select [Low Adjustment] in the menu, press [OK] button, and enter [Low Adjustment], displayed as follows:



Figure 6-6. Low-level adjustment and editing interface

Table 6-11 Description of low-level adjustment

	RD800X (General version)	RD800X (Small blind area with high precision)	RD800X (Mass range)
The parameter name	Low adjustment		
Parameter Range (m)	1~ The scale	1~ The scale	1~ The scale
Windows default (m)	60	30	120
Affiliate configuration	(1) If the set low adjustment is less than (high adjustment point + 0.5), the low adjustment point is set to (high adjustment point + 0.5); (2) The corresponding position of 4 mA,When the current output function is the position, 4 mA and low adjustment point correspond, and modified at the same time; (3) 20 mA,When the current output function is empty high, 20 mA and low adjustment point correspond, and modified at the same time;		
Option meaning	In case the current output function is the position, it corresponds to 4 mA; When the current output function is empty high, it corresponds to 20 mA;		
Special matters	Not have		

6.5.1.5. [High adjustment]

[High level adjustment] involves [low level adjustment] Settings. It maps the measurement to the current output (4-20 mA).[Basic setting] Select [High Adjustment] in the menu, press [OK] button, and enter [High Adjustment], and display as follows:

Table 6-12 High-level adjustment description

	RD800X (General version)	RD800X (Small blind area with high precision)	RD800X (Mass range)
The parameter name	High adjustment		
Parameter Range (m)	0~ (Low adjustment point-0.5)	0~ (Low adjustment point-0.5)	0~ (Low adjustment point-0.5)
Windows default (m)	0	0	0
Affiliate configuration	(1) If the set high adjustment is greater than (low adjustment point-0.5), the high adjustment point is set to (low adjustment point-0.5); (2) The corresponding position of 4 mA, When the current output function is empty high, 4 mA and high adjustment point correspond, and modified at the same time; (3) 20 mA, When the current output function is the position, 20 mA and high adjustment point correspond, and modified at the same time;		
Option meaning	When the current output function is the object position, it corresponds to 20 mA; When the current output function is empty high, it corresponds to 4 mA;		
Special matters	Not have		



Figure 6-7 High-level adjustment and editing interface

6.5.1.6. [Blind area setting]

Enter the [Basic Settings] menu, select the [Blind Area Settings], press the [OK] button, and enter the option to edit the blind area range, as shown below. If you need to modify the value, follow the 6.6 keyboard menu editing operation.



Figure 6-19 Blind spot setting and editing interface

Table 6-15 Description of the blind area

	RD800X (Solid state)	RD800X (Liquid)	RD800X (Solid state)
The parameter name	Fade zone		
Parameter Range (m)	0~ (Range-0.5)	0~ (Range-0.5)	0~ (Range-0.5)
Windows default (m)	0	0	0
Affiliate configuration	(1) If the set high adjustment is greater than (low adjustment point-0.5), the high adjustment point is set to (low adjustment point-0.5);		
Option meaning	Echo areas smaller than the blind area are not selected		
Special matters	Not have		

6.5.1.7. [Scale setting]

In order to measure the correct result, the range range of the instrument should be set. Select the [Basic Settings] menu and enter the [range setting] option. If you need to modify the value, edit the 6.6 keyboard menu.



Figure 6-20 Setting setting editing interface

Table 6-16 Scale range description

	RD800X (Solid state)	RD800X (Liquid)	RD800X (Solid state)
The parameter name	High adjustment		
Parameter Range (m)	1~60	1~30	1~120
Windows default (m)	60	30	120
Affiliate configuration	(1) Blind zone, if the range value is less than (blind zone + 0.5), the range is automatically set to (blind zone + 0.5) (2) The corresponding position of 4 mA, When the current output function is distance, 4 mA corresponds to the position and range, and is modified at the same time; Set the quantity relationship: Blind zone + 0.5 <= range		
Option meaning	The echo region greater than the range is not selected		
Special matters	Not have		

6.5.1.8. [Damping period]

In order to improve the stability of the measured output value, a larger [damping time] can be set to stabilize the measurement value and increase the anti-interference ability. For example, the damping time is 2 seconds, the position of the measured object has a step change at time t, the measured output value follows the actual position of the measured object after 10 seconds, enter the [basic setting] menu, select [damping time], press [OK], and display as shown in the following figure:



Figure 6-8 Damping time editing interface

Table 6-13 Description of the damping time

	RD800X	RD800X	RD800X
The parameter name	Damping period		
Parameter Range (m)	0~600		
Windows default (m)	60		
Affiliate configuration	Not have		
Option meaning	Damped output to improve signal stability		
Special matters	Not have		

6.5.1.9. [Sensor mode]

[Sensor mode] The output form of the measured value can be selected according to the field needs. Enter the [Basic Settings] option to enter the [Sensor Mode], displayed as follows:



Table 6-9 Sensor mode editing interface

Table 6-14 Description of the sensor mode

	RD800X	RD800X	RD800X
The parameter name	Sensor mode		
Windows default (S)	Distance		
Affiliate configuration	Not have		
Option meaning	Distance: Measured value quantity =measured distance Position: measured value =low adjustment point-measured distance (minimum:0) Empty height: Measured value =measured distance-high adjustment point (minimum:0)		
Special matters	When the range is set to be greater than the low adjustment point, sometimes the measurement distance will be greater than the low adjustment point, then the measured level is 0; When the measurement distance will be less than the high adjustment point, then the measured empty height is 0;		

6.5.2 Displays the menu operation

6.5.2.1. [Parasang]

Set [distance units] can display the measured values corresponding to different units. Enter the [Display] menu, select the [Distance Unit], and display as follows:



Table 6-10 Distance from the unit editing interface

6.5.2.2. [Degree-day]

Set [temperature units] can display the measured temperature values corresponding to different units. Enter the [Display] menu, select the [Temperature Unit], and display as follows:



Table 6-11 temperature unit editing interface

6.5.2.3. [Display language]

Set [Display Language], suitable for users in different countries, currently support Chinese. Enter the [Display] menu, select the [Display Language], and display as follows:



Table 6-12 shows the language editing interface

6.5.3 Diagnostic menu operation

6.5.3.1. [Evolution curve]

See "Echo curve interface description".

6.5.3.2. [Historical curve]

After setting [sensor mode] object level / air height / distance / volume, running the measurement interface can display the corresponding measurement value, [historical curve] can count the measurement value in [historical time], and draw it into a curve. Enter the [Diagnostics] menu and select [History Curve] as follows:



Table 6-18 History curve display interface

6.5.3.3. [Historical Time]

Set the time range of [historical curve], and the interface of [historical curve] displays the data curve in the corresponding time period according to this setting. Enter the [Diagnostic] menu, select [History Time], edit the time required, display as follows:



Table 6-17 Historical time editing interface

Note: The time is set to even numbers between 2-120.

6.5.3.4. [Historical measurement peak value]

[Historical measurement peak] The highest value and lowest value of the measured value after the factory can be counted. Enter the [Diagnostic] menu, select the [Measurement Peak] menu, select [Read], read the lowest and highest measurements, select [Clean] Clear history measurement statistics, and display as follows:



Table 6-13 Historical measurement peak display interface

6.5.3.5. [Historical temperature peak]

[Historical temperature peak] The highest value and the lowest value of the temperature measured value after the factory can be counted. Enter the [Diagnostic] menu, select [Historical Temperature Peak] menu, select [Read], read the lowest and highest temperature measurements, select [Clean] clear historical measurement statistics, and display as follows:



Table 6-14 Historical temperature peak display interface

6.5.3.6. [Historical feed rate]

[Historical feed rate] The highest value and lowest value of the material rate set by the meter after the factory. Enter the [Diagnostic] menu, select the [Historical Feed Rate] menu, select [Read] to read the lowest and highest feed rate value, select [Clean] to clear the historical statistics, and display as follows:



Table 6-15 Historical feed rate display interface

6.5.3.7. [Historical discharge rate]

[Historical discharge rate] The highest value and the lowest value of the discharge rate set after the instrument leaves the factory. Enter the [History Diagnosis] menu, select the [Release Rate] menu, select [Read], read the lowest and highest discharge rate value, select [Clean] clear history statistics, and display as follows:



Table 6-16 The historical discharge rate display interface

6.5.4 Service menu operations

6.5.4.1. [False-echo learning]

[False echo learning] It can learn false echoes in the container of known obstacles, and form the screening curve (threshold curve) of background noise. Before learning false echo, [false echo mode] should be set and [false echo region]. Enter the [Basic Settings] menu and select [False Echo Learning] as shown in the figure below.



Table 6-29 False-echo learning editing interface

6.5.4.2. [Restore the factory]

To restore the instrument factory settings. Enter the [Professional Settings] menu and select [Recovery factory]. The recovery time is about 15s to 20s. After restoring the factory Settings, the system will automatically jump to the main interface. Shown as follows:



Table 6-21 Restoring the factory editing interface

6.5.4.3. [Rate of feed]

[Feed rate] is used to adjust the response rate of the instrument to the actual material level increase. When the feed rate is changed, the response rate will automatically changed. Enter the [Basic Settings] menu and select [Feed Rate], displayed as follows:



Table 6-32 Feed rate editing interface

6.5.4.4. [Discharge Rate]

[Release rate] It is used to adjust the response rate of the instrument to the actual material level reduction. When the discharge rate changes, the response rate automatically changes. Enter the [Basic Settings] menu and select [Release Rate] as follows:



Table 6-33

Table 6-24 Description of the inlet and outlet material speed

	RD800X	RD800X	RD800X
The parameter name	Feed rate and discharge rate		
Parameter range (m / min)	0~300		
Default value (m / min)	0.1		
Affiliate configuration	Not have		
Option meaning	Sets the response rate for item tracking		
Special matters	It is only valid in the non-unlocked mode		

6.5.4.5. [Current Simulation]

Set the specific value of the manual output current to meet the needs of different working conditions. Enter [Service] and select [Current Simulation] as follows:



Table 6-28 Editorial interface of the current output function

Table 6-21 Description of manually input values

	RD800X	RD800X	RD800X
The parameter name	Enter the value manually		
Parameter Range (mA)	4 ~ 20		
Windows default (mA)	4		
Affiliate configuration	This option is useful to select the current output function as manual		
Option meaning	Manually set the output value of the current		
Special matters	Not have		

6.5.4.6. [4 mA position]

Set [4 mA position], when the measured value is [low adjustment], output 4 mA, the user can customize the 4 mA position of 4-20 mA output according to the actual needs, enter [professional Settings], select [4 mA position], display as follows:



Table 6-26 4 mA position editing interface

6.5.4.7. [20 mA position]

Set [20 mA position], when the measurement value is [high adjustment] value, output 20 mA, the user can customize the 20 mA position of 4-20 mA output according to the actual needs, enter [professional Settings], select [20 mA position], display as follows:



Table 6-27 20 mA position editing interface

Table 6-20 4 mA / 20 mA position description

	RD800X	RD800X	RD800X
The parameter name	At 4mA, 20 mA positions		
Parameter Range	0~120		
Windows default	<p>When the current output function is distance, positions of 4 mA and 20 mA correspond to 0 and range respectively;</p> <p>When the current output function is the position, the positions of 4 mA and 20 mA correspond to low and high adjustment points respectively;</p> <p>When the current output function is empty high, the positions of 4 mA and 20 mA respectively correspond to the high and low adjustment points;</p>		
Affiliate configuration	Not have		
Option meaning	Set the correspondence of the analog output		
Special matters			

6.5.4.8. [Current-output function]

Set [current output function] to meet the needs of different working conditions. Enter [Professional Settings], select [Current output function], and display it as follows:



Table 6-24 Editorial interface of the current output function

Under the different options, the relationship between the simulated quantities is shown in the figure below:

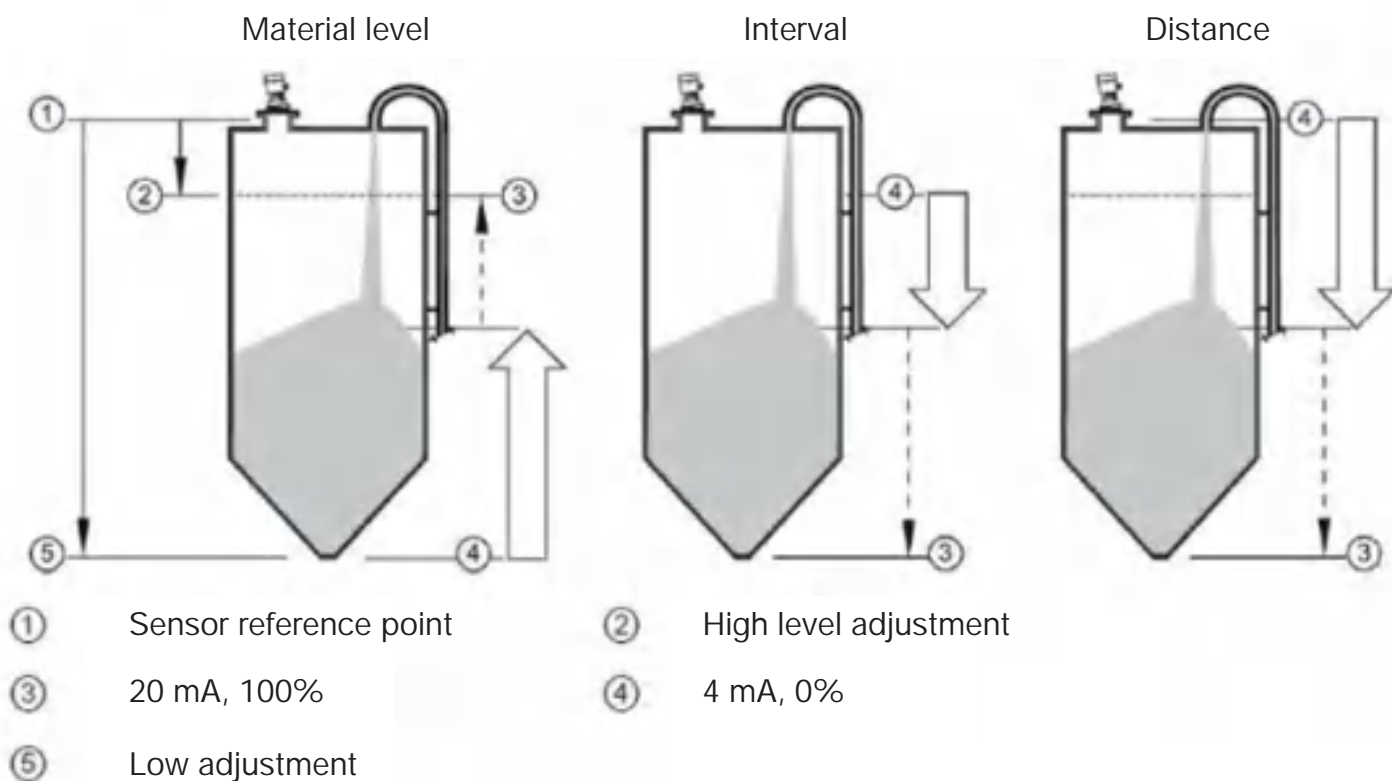

Table 6-25 Schematic diagram of the current output function

Table 6-19 Description of the current output function

	RD800X	RD800X	RD800X
The parameter name	Current-output function		
Windows default	Object position		
Affiliate configuration	(1) The corresponding position of 4 mA, When the current output function is the distance, the corresponding position of 4 mA is modified to match the corresponding range; When the current output function is the object position, the corresponding position of 4 mA is modified to correspond to the low adjustment point; When the current output function is empty high, the corresponding position of 4 mA is modified to correspond to the high adjustment point; (2) 20 mA, When the current output function is the distance, the corresponding position of 20 mA is modified to 0; When the current output function is the object position, the corresponding position of 20 mA is modified to correspond to the high adjustment point; When the current output function is empty high, the corresponding position of 20 mA is modified to correspond to the low adjustment point;		
Option meaning	Set the way of the analog output		
Special matters	When selected as the manual output, the analog output corresponds to the manual input value in the current calibration menu		

6.5.4.9. [Bus Address]

Set different [bus address] into the working site network. Enter [Professional Settings] and select [Bus Address] as follows:



Table 6-22

Table 6-17 Bus address description

	RD800X	RD800X	RD800X
The parameter name	Bus address		
Parameter Range	1-247		
Windows default	1		
Affiliate configuration	Not have		
Option meaning	Set the address of the machine 485 communication		
Special matters	Not have		

6.5.4.10. [Distance offset]

Set the [distance offset] to correct the deviation between the ideal measurements and the actual measurements. Enter [Professional Settings], select [Distance Offset], and display it as follows:



Table 6-23 Distance offset editing interface

Table 6-18 Description of the distance offset

	RD800X	RD800X	RD800X
The parameter name	Distance offset		
Parameter Range (m)	-10 ~ 10		
Windows default (m)	0		
Affiliate configuration	Not have		
Option meaning	Correct the deviation of the ideal measurements and the actual measurements		
Special matters	Not have		

6.5.4.11. [Fault output current]

Set [fault output current] to set the value of the actual output current when the instrument encounters a fault. Enter the [Professional Settings] menu, select [fault output current], displayed as follows. The hold option represents the last effective measured current of the output



Table 6-34 The fault output current editing interface

6.5.4.12. [Fault timer]

Set [fault timer], When the instrument does not find the echo within the set time, output the fault code 0001, and the current output refers to the fault current output option in the professional setting. The default is 100s, and the range is 0-1000s. Enter [Professional Settings], select [fault Timer], and the display is as follows:



Table 6-35

6.5.5 Information menu operations

6.5.5.1. [Sensor Model]

In the parameter setting interface, select [Information], press [OK] to enter the option, select [Display and Control version], press [OK] to enter, and the graphical interface displays as follows:



Table 6-38 Sensor model display interface

6.5.5.2. [Sensor label]

In the field, to distinguish between the different sensors. With 8 characters, each character can be set to '0 ~ 9 or A to Z; in the setting parameter interface, select [Information], press [OK] to enter option, select [Sensor tag], press [OK] to enter, the graphical interface is as follows:



Table 6-39 Sensor label display interface

6.6 Keyboard menu editing operation

When editing the digital editing menu options, such as blind spot setting and range setting, you need to edit the number bar. Such as the blind area setting for example.



Table 6-40 digital editing

Press [DN] to move the cursor cycle right. After moving right to the last bit, the cursor returns to the far left. As shown in the figure below:



Table 6-41 [DN] Key for Cursor Right Move (1)



Table 6-42 [DN] Key for Cursor Right Move (2)

Press [UP] to cycle the number from 0 to 9



Table 6-43 [UP] key realizes the number modification at the cursor

Press the [OK] key to complete the setting, and the measurement and control terminal returns to the confirmation state, and display the "OK" in the lower right corner of the interface for 1 second.



Table 6-44 Confirmation status diagram of measurement and control terminal

7. Glossary

Precision: the consistency of the measured values with the standard or true values.

Stirator: Mechanical device for mixing or inflation. A device that produces fluctuations.

Algorithm: a specified explicit rule or procedure for a problem.

Ambient temperature: the temperature of the air surrounding the equipment housing.

Antenna: an antenna that transmits and receives signals from the specified direction. Generally, there are four kinds of antennas in the object position radar measurement: horn shape, rod shape, parabolic shape and waveguide rod.

Decay: It is used to represent the decrease in the median amplitude of the signal propagation from one point to another point. The attenuation can be expressed by the purity ratio of the input amplitude to the output amplitude.

Beam angle: the beam angle with half the energy as a limit (-3dB).

Beam divergence: The beam is dispersed through a certain medium.

Blind area: a section of non-inductive area from the reference point plus an additional shielding length. The meter will ignore this area when processing.

Capacitance: the properties of a system composed of conductors and insulators, which can store the current when there is a voltage difference between the conductors. The value is expressed as the ratio of the number of current to the voltage difference in Faraday (Farad).

Confidence level: to describe the echo quality. High values indicate high quality. The Confidence threshold defines the minimum value. D B (dB): the unit of signal amplitude.

Insulator: material that does not conduct direct current. (Many conductive liquids also have dielectric properties; the dielectric constant of water is 80)

Dielectric constant (DK): the ability of a dielectric to store electricity under electromagnetic field induction. Often called the relative dielectric constant. The increase of the dielectric constant is directly proportional to the increase of the signal amplitude. The value is generally relative to the vacuum / dry air: the dielectric constant of the air is 1.

Echo: the reflected signal, the amplitude is large enough, and can be distinguished from the emitted signal in a certain way is called the echo. Echo are associated with directly emitted signals and are frequently measured in decibels.

Echo confidence: recognition of an effective echo. A measure of echo reliability.

Echo processing: the process that the radar unit determines the echo wave.

Echo strength: describe the intensity of the selected echo above 1 μV rms in dB.

Transmission cone: extension of antenna angle.

False echo: the echo of any echo that is not the desired target. In general, the false echoes are generated by the obstacles of the container.

Frequency: the number of occurrence times per unit of time. The frequency can be specified as a cycle per second.

Hertz (Hz): frequency unit, one cycle per second. 1 GHz equals 10⁹Hz.

Horn antenna: Conical, horn-shaped antenna can focus the microwave signal. The larger the horn size, the more focused the radar beam is.

Inductor: Different current senses an electromotive force in the circuit or in an adjacent circuit. The unit is Henry.

Microwave: the electromagnetic wave frequency is within the radar frequency spectrum range. (1GHz to 300GHz)

Multiple echo: The secondary echo occurring at the target echo distance may be a double, triple or quadruple echo

Riser: Pipe on the upper section of the vessel used to install the flange.

Parameter: Change some variables to constant according to the specified purpose or process.

Polarization: the emitted electromagnetic wave properties, describing the direction and amplitude of the electric field vector changing over time.

Radar: radar is the short write mode of Radio Detection And Ranging. Eit and use devices that reflect electromagnetic waves by the target to determine the target distance or location.

Range: the distance between the transmitting electrode and the target.

Range extension: distance below container 0% or empty point.

Repeatability: Measure the multiple measurement proximity of the same variable in the same condition.

Shooting: a firing pulse or measurement.

Speed of light: the velocity of electromagnetic waves (including electromagnetic waves and light in free space.) The speed of light is 299,792,458 m per second.

Diameter pipe: a pipe installed in the wall of the container and open at the bottom of the container.

Two-line (system) radar: low-energy radar. Can loop power supply, analog, security, or digital (BUS) transmission.

Threshold curve: a curve over time, as a threshold, over which the echo is considered valid.